

## Optimization of Ethylene Refrigeration System Using Genetic Algorithms Method

Dr. Shurooq Talib Al-Hemeri \*; Dr. Mumtaz A. Yousif \*; Dr. Ahmed M. AL Barifcani\*\*

\*Chemical Engineering Department, UOT, \*\*Ministry of Oil

### Abstract:

Ethylene refrigeration for gases separation at low temperature and high pressure for olefin production is an important technique in the chemical industry. Since small changes in the operating conditions of such a process can have a significant influence on its economics, optimization is desirable. The present work was aimed to propose and establish a mathematical model for the ethylene refrigeration system of the ethylene plant in Basrah petrochemical complex NO.1 (PC1) and reformulated as a geometric programming problem using Visual Basic for predicting:- (overall efficiency of the ethylene refrigeration system  $\{\% \eta\}$  and percent of energy saving %E). Through the formulated model shaft work consumption by the centrifugal compressor, refrigeration effect and coefficient of performance of the system were obtained and other parameters concerning the system. The results of simulation showed a good agreement with the manufacturer manual. In this study the effect of four factors as independent variables on the overall refrigeration system efficiency and percent of energy saving were studied ;evaporator low pressure ( $P_L$ ) in the range of (1-3)bar ,compressor discharge high pressure ( $P_h$ ) in the range of ( 28-32)bar ,condenser degree of sub-cool temperature ( $T_{sub-D}$ ) in the range of (6-22) $^{\circ}C$  and evaporator degree of superheat temperature ( $T_{sup-D}$ ) in the range of (1-5) $^{\circ}C$ . And the optimum conditions that aimed to minimize the thermodynamic irreversibility i.e (maximize overall refrigeration system efficiency) and also lower operating cost i.e (maximize percent of energy saving) evaporator low pressure ( $P_L$ ) (2.8 bar), compressor discharge high pressure ( $P_h$ ) (28.7 bar), condenser degree of sub-cool temperature ( $T_{sub-D}$ ) (19 $^{\circ}C$ ), and evaporator degree of superheat temperature ( $T_{sup-D}$ ) (3.4 $^{\circ}C$ ). At these conditions the overall refrigeration system efficiency is (81.8%) and percent of energy saving is 51.18% with respect to conditions in the factory.

**Keyword:** Refrigeration System, Genetic Algorithms, Ethylene Plant, Optimization Method.

## إختيار الظروف المثلى لأنظمة تبريد الأثيلين باستخدام طريقة الخوارزمية الجينية

### الخلاصة:

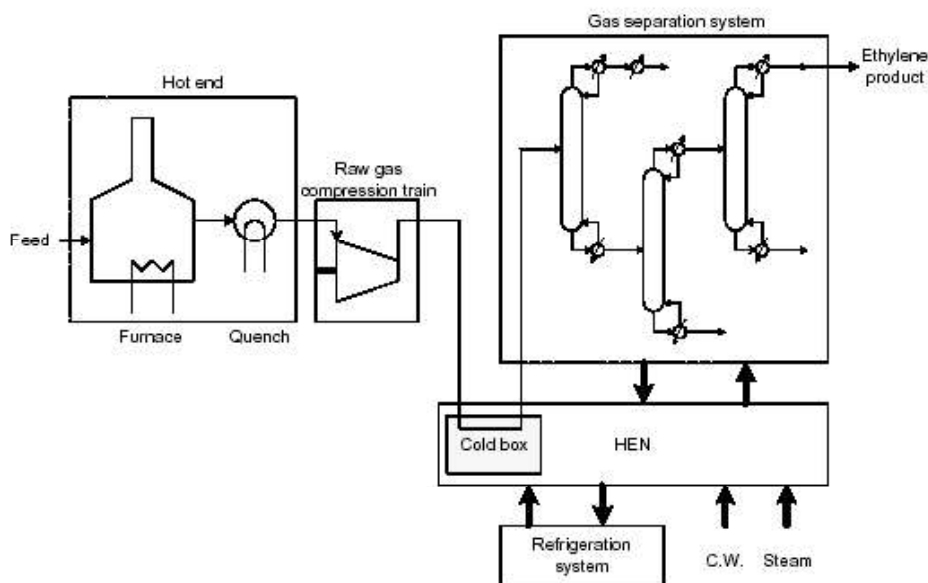
إن أنظمة التبريد باستخدام غاز الأثيلين كمادة تبريد من العمليات المهمة لأغراض فصل الغازات في الصناعات الكيماوية عند الضغط العالي و درجة الحرارة الواطئة. و لهذا فإن أي تطور بالظروف التشغيلية للنظام ولو كان قليلاً فإنه يؤثر بشكل ملحوظ على اقتصاديات العملية أي إنه يوفر الكثير من المال . الدراسة الحالية تهدف لإقتراح موديل رياضي لنظام تبريد الأثيلين الموجود في وحدة الأثيلين في المجمع البتروكيماوي رقم (1) و قد تم بناء برنامج بالحاسبة الإلكترونية بلغة (Visual Basic) يستخدم لتحديد الكفاءة الكلية للدورة و النسبة المؤية لحزن الطاقة و بمختلف الظروف التشغيلية و تم من خلاله حساب الشغل المستهلك بواسطة الضاغطة المركزية و سعة التبريد و معامل اداء النظام بالإضافة إلى العديد من العوامل المتعلقة بالنظام . إن نتائج التحليل الرياضي أظهرت تقارب جيد بين القيم الناتجة من عمل البرنامج و بين القيم الحقيقية لنظام التبريد حيث تم دراسة أربعة متغيرات رئيسية في الدورة هي ضغط المبخرات المنخفض ، الضغط العالي الناتج من الكابسة ، درجة الحرارة الناتجة من المكثفات و درجة الحرارة الناتجة من المبخرات و ضمن المدى (1-3) bar ، (28-32) bar ، (6-22)°C و (1-5)°C على التوالي . وكانت النتائج التي تم الحصول عليها هي : (2.8 bar) لضغط المبخرات المنخفض ، (28.7 bar) للضغط العالي الناتج من الكابسة ، (19°C) لدرجة الحرارة الناتجة من المكثفات و (3.4 °C) لدرجة الحرارة الناتجة من المبخرات . و نتائج الدراسة أظهرت إن زيادة ضغط المبخرات المنخفض يؤدي إلى تحسن الكفاءة في النظام و كذلك زيادة حزن الطاقة لكن الزيادة بالضغط العالي الناتج من الكابسة يؤدي إلى خفض كفاءة النظام و التقليل من حزن الطاقة .

الكلمات الدالة: أنظمة التبريد ، الخوارزمية الجينية ، مصنع الأثيلين ، طرق أختيار الظروف المثلى.

### Introduction

In the chemical process industry (CPI), most relatively simple organic chemicals are produced such as ethylene, propylene and benzene. These chemicals (some through intermediates, e.g. mono vinyl chloride or styrene) form the building blocks for many products such as plastics, resins, fibres, detergents, etc [1]. In olefins plants, considerable refrigeration is required to separate the low-boiling products. Many industrial processes (petroleum refineries, petrochemical industries) generate waste heat sources, which are potentially usable in thermal processes i.e (45 to 50) % of heat removed by ethylene refrigeration system. The relation between energy requirement at refrigeration usage at different temperatures have been found to be very useful in evaluating alternative process arrangements in the ethylene recovery unit [2]. An ethylene recovery plant comprises of several parts: the hot-end utilities, the raw gas compression train, the gas separation system and the cold-end utilities. In the cold-end

utilities, a refrigeration system interacts with the process through the HEN and cold box. Figure (1) illustrates the ethylene recovery plant diagrammatically [3]:



**Fig. (1) Simplified process flow diagram of an ethylene recovery plant [3].**

Generally pure compounds like ammonia, Freon, propylene, propane, ethylene, ethane, etc., are used as refrigerant in closed refrigeration circuits, therefore, the refrigeration process can be divided into low temperature heat transfer fluids that are crucial components in many applications. Current heat transfer fluid technology includes direct refrigerant and the refrigeration technique [4,5]. All cooling processes may be classified as either sensible or latent according to the effect of the absorbed heat upon the refrigerant. The operating costs for refrigeration systems are often dominated by the cost of shaft work to drive the compressors. In sub-ambient processes, such as ethylene plants and natural gas liquefaction plants, design of refrigeration systems is the major concern for energy consumption [6].

Applying the study ensures many advantages, among them are:

1. Ethylene refrigeration system is an important part of ethylene production in the petrochemical industry, because of the complex cycle and plants is that high operating cost and very expensive compressors are involved.

## No.13 Journal of Petroleum Research & Studies (JPR&S)

2. Low temperature / cryogenic processes are cost- effective for the recovery of valuable products such as ethylene, propylene, charge gas, natural gas from process gas streams. Each process requires energy extraction "cold" at various temperature levels for the process to work efficiently.
3. Hydrocarbon refrigerants such as ethylene have been used quite economically over a wide range of cooling temperatures from (-50) °C to (-145) °C.
4. Revamping of ethylene plant cool- down trains and the associated demethanizer on the existing facilities is often an attractive investment proposition as it increases fractionation capacity at minimum cost and minimum downtime.

### Aim of the Present Study

Now the ethylene plant will be revamped for a different feedstock to produce more ethylene and also propylene which involves changes of loads at low temperature condensers and coolers that are involved with ethylene refrigeration system. This work is the first local contribution in studying optimization technique " Genetic Algorithm Method " to energy saving and improvements of the performance for ethylene refrigeration system existing in the ethylene unit in Basrah petrochemical complex No.1 (PC1). It is a necessary to start with the utmost attention being paid to thermodynamic fundamentals, which can be easily extended to analysis of the industrial ethylene refrigeration cycle. The main goal of this work is to computationally simulate the actual processes and optimize the percentage energy saving and overall performance efficiency for ERS. In order to achieve this task, the following sequence has been followed:

- a) The development of a computer program that simulates the material and energy balances for the present ERS and predict of the compressor in the cycle.
- b) The study of the effect of the main operating variables (evaporator low pressure, compressor discharge high pressure, evaporator degree of superheat temperature and condenser degree of sub-cool temperature) on the overall performance efficiency and the percent of energy saving.

- c) The optimization of the studied operating variables for maximum performance efficiency and energy saving.

## Mathematical Model and Implementation

### 1) Ethylene Refrigeration System Under Study

Ethylene plant in Basra Petrochemical Complex (PC1) utilizes an ethylene refrigeration cycle. This cycle involves a centrifugal compressor having three stages, five condensers of shell and tube type, nine kettle type evaporators, eleven expansion valves and two (vapor – liquid) separators. The cycle provides three levels of refrigeration [7], as shown in figure (3). Because the main process involves high pressure refrigeration of low boiling point components, such as methane, ethane, etc., several very low temperature levels of refrigeration are required for process stream cooling [8]. A refrigeration process involving ethylene as refrigerant is designed for this study.

In vapor compression refrigeration cycles, heat is removed from the process by boiling a liquid refrigerant at low pressure, and thus, low temperature. The vapor is compressed to a higher pressure at which the heat of vaporization can be removed at a convenient higher temperature. The critical temperature of ethylene (about 9.5 °C) is below ambient temperature. Thus, ethylene cannot be condensed by air or cooling water. Rather, ethylene is condensed as it boils a liquid propylene refrigerant [9]. The physical properties of ethylene showed in the table (1).

**Table (1):- Thermo physical Properties of Ethylene(Heinz and Roland;2001)**

Molecular Weight	28.0536
Triple Point :	
Temperature	-169.19 °C
Pressure	0.11 Kpa
Latent Heat of Fusion	119.5 KJ/Kg

## No.13 Journal of Petroleum Research & Studies (JPR&S)

Normal Boiling Point :	
Temperature	-103.71 °C
Latent Heat of Vaporization	488 KJ/Kg
Density of the Liquid	570 Kg/m <sup>3</sup>
Specific Heat of the Liquid	2.63 KJ/Kg. °C
Viscosity of the Liquid	1.61*10 <sup>-4</sup> poise
Surface Tension of the Liquid	0.0164 N/m
Critical Point :	
temperature	9.2 0C
Pressure	5.042Mpa
Density	210 Kg/m3

### 1) Operating Cycle

The operating cycle is demonstrated on a P-h diagram as follows [10]:

#### STATE POINTS 1-2

A liquid-gas mixture of refrigerant enters the evaporator at state point 1. The process cooling load,  $Q_e$ , is absorbed from the chilled ethylene system by the liquid refrigerant, vaporizing the liquid to state point 2.

#### STATE POINTS 2-3

The refrigerant vapor flows from the evaporator into the first stage of the centrifugal compressor. This distance represents the heating of the vapor into a super heated condition. Note that little heat has been added and that the pressure and temperature are raised to that corresponding to state point 3.

**STATE POINTS 3-4**

The refrigerant gas compressed to state point 3 and mixed in the first to second stage crossover with some cooler refrigerant gas from the economizer ( $E_{co2}$ ).

**STATE POINTS 4-5**

Refrigerant gas in the first to second stage crossover pipe is now drawn into the second stage of the compressor. Here the refrigerant gas pressure and temperature are raised to that corresponding to state point 5.

**STATE POINTS 5-6**

The refrigerant gas is compressed to state point 5 and mixed in the second to third stage crossover with some cooler refrigerant gas from the economizer ( $E_{co1}$ ).

**STATE POINTS 6-7**

Refrigerant gas in the second to third stage crossover pipe is now drawn into the third stage of the compressor. Here the refrigerant gas pressure and temperature are raised to that corresponding to state point 7.

**STATE POINTS 7-8**

The refrigerant gas enters the condenser at state point 7. Here the process cooling load  $Q_c$ , plus the power input to the compressor, is rejected to the condenser ethylene. The rejection of the total condenser load,  $Q_c$ , occurs at a constant pressure  $P_c$ . The rejection of heat cools and condenses the hot refrigerant gas to a liquid at state point 8.

**STATE POINTS 8-9**

Liquid refrigerant exiting the condenser at state point 8 flows through the first level of expansion valve and enters the economizer. And the vapor outlet from economizer enters to the compressor third stage at a pressure  $P_{II}$ .

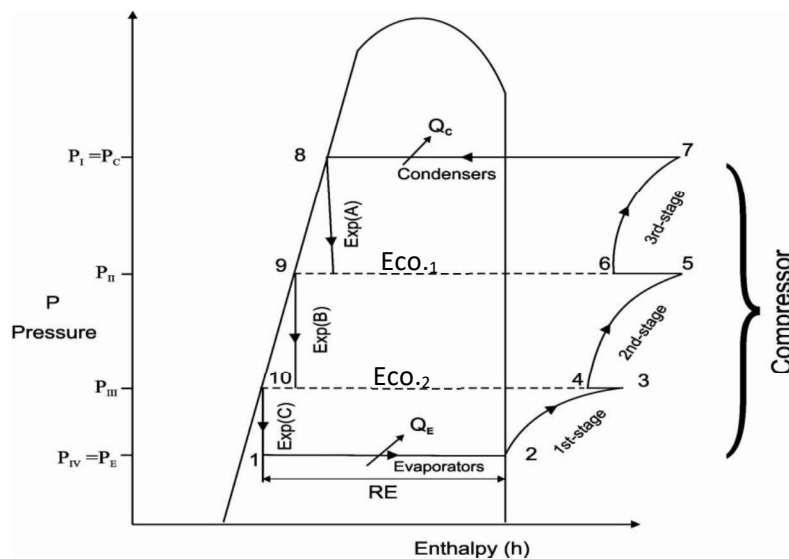
## No.13 Journal of Petroleum Research & Studies (JPR&S)

### STATE POINTS 9-10

Liquid refrigerant exiting economizer 1 is reduced by expansion valve second level, and enters economizer 2 at a pressure ( $P_{III}$ ), intermediate to the evaporator. And the vapor outlet from economizer enters to the compressor second stage at a pressure  $P_{III}$ .

### STATE POINTS 10-1

The liquid exiting economizer 2 now flows to the third level where the refrigerants pressure and temperature are reduced to the evaporator conditions. It is important to note the pressure difference between the evaporator and condenser as shown on the pressure-enthalpy diagram. The pressure difference,  $P_c - P_e$ , is the pressure differential or head pressure that must be produced by the centrifugal compressor for the cycle to operate. Figure (2) shows the sketch (P-h) diagram for the ideal ethylene refrigeration cycle.



e

**Fig.(2) Pressure- Enthalpy Diagram**

e



## Modeling of Ethylene Refrigeration Cycle

### a- Model Assumptions

In constructing the system model, the following major assumptions were made:

1. Pressure drops for the refrigerant side in the heat exchanger and piping are negligible (Wright;2005).
2. Expansions across the valves are isenthalpic (Smith;1987).
3. Polytropic efficiency in the three stages of the compressor is equal to( 0.8) (Ludwig;1986).
4. Compression is non-adiabatic and the vapour in the superheat region is incompressible (Ludwig;1986).

### B-Model Equations

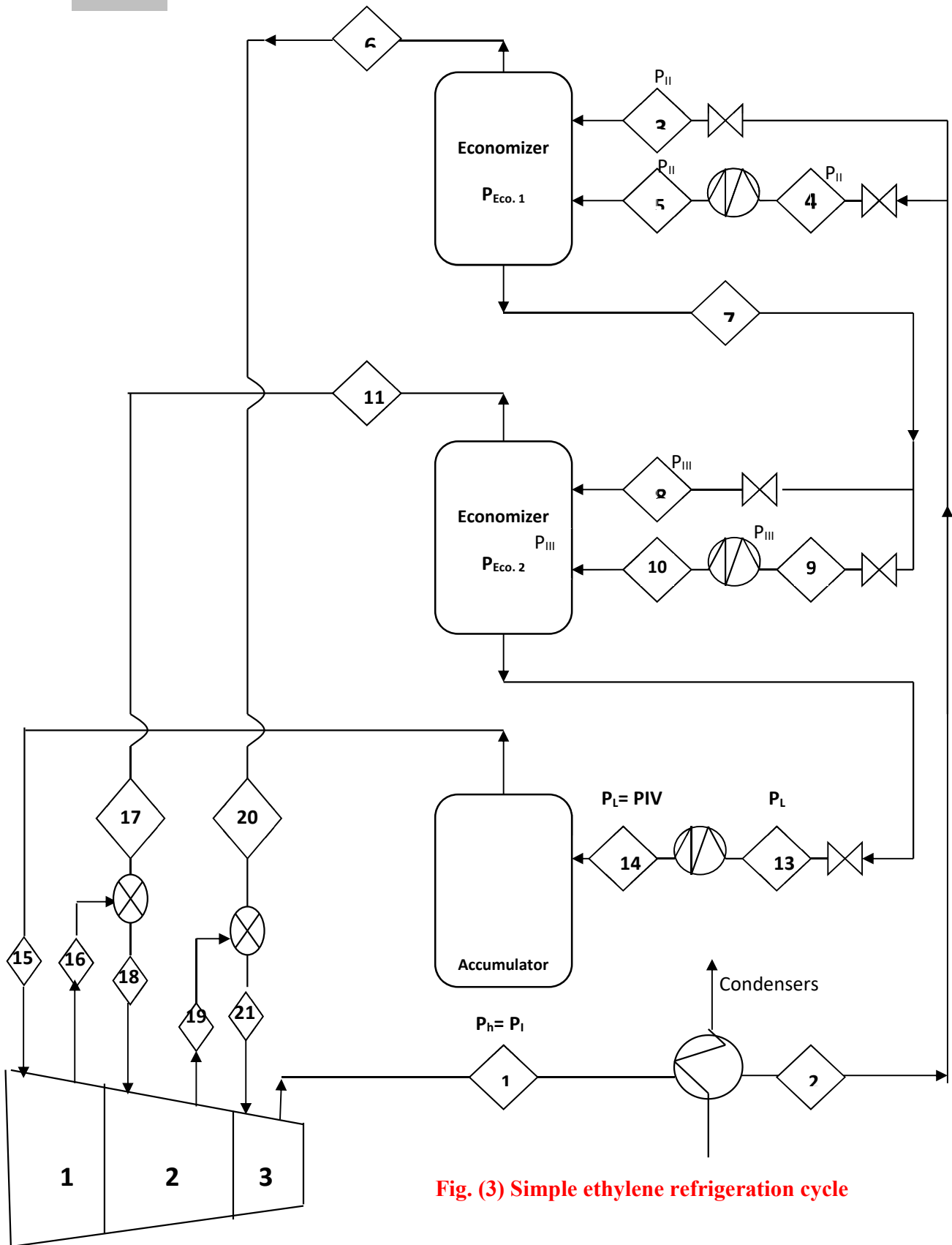
To aid in the organization of the modelling of refrigeration process, a simplification of the ethylene refrigeration system was used. Figure (3) represents the conventional ethylene refrigeration cycle for optimization. In this cycle, there are three levels, therefore each of economizer (vapour-liquid) separator and accumulator were operated at different pressures. Hence by starting from the stream output at the third stage from the centrifugal compressor, the stream was numbered as Node 1 and the stream output from the condensers as Node 2, then counting from the bottom to the top as shown in the figure. The evaporators were operated at three- levels of pressure ( $P_{II}$ ,  $P_{III}$ ,  $P_{IV}$ ), the last Node was numbered 21 which is the stream input to the third stage of compressor. Making the material and energy balances on the various sections of the cycle, and by further simplifications of equations lead to the final model. In order to quantitatively evaluate the performance of the ethylene refrigeration system, a vapour compression refrigeration cycle is used, the overall efficiency is expressed in terms of cooling coefficient of performance or the COP of actual irreversible compression to the ideal reversible compression.

**No.13 Journal of Petroleum Research & Studies (JPR&S)**

$$\eta_{overall} = \frac{COP_{actual}}{COP_{ideal}} * 100 \dots\dots\dots(1)$$

$$E_{conse.} = \frac{M \cdot * Q_{comp}}{1000} \dots\dots\dots(2)$$

$$E_{saving} = \frac{FE - E_{cons.}}{FE} * 100 \dots\dots\dots(3)$$



**Fig. (3) Simple ethylene refrigeration cycle**

## **2) Optimization By Genetic Algorithms Method (GAs)**

Refrigeration system optimization can be defined as a process that produces the desired refrigeration effect at minimum cost. As energy become more expensive, the need for optimizing existing system will continue to grow [11].

The interest in GAs and their applications grew over the past few years due to a number of reasons. Some of these are [12]:

1. GAs considers many points in the search space simultaneously and therefore have a reduced chance of converting to local minimum.
2. GAs work directly with the strings of characters representing the parameter set, not the parameters themselves. Thus GAs is more flexible than most search methods.
3. GAs use probabilistic rules to guide search, not deterministic rules.

The problem formulation of any optimization problem can be thought of as a sequence of steps. In the present study, coefficient of performance for ethylene refrigeration cycle and energy saving of the refrigeration system are to be optimized and the following steps are followed:

- Choosing operating variables ( $P_h$ ,  $P_L$ ,  $T_{sup-D}$ ,  $T_{sub-D}$ ).
- Formulating constraints. (Given process conditions).
- Formulating objective function (overall efficiency, percentage energy saving).
- Setting up variable bounds (discrete value for each variable).
- Choosing method (genetic algorithm).
- Obtaining the solution (arriving at maximum overall efficiency and percentage energy saving).

## No.13 Journal of Petroleum Research & Studies (JPR&S)

The entire strength of GA lies in the three genetic operators: selection, crossover and mutation, which make it a robust optimization technique. Selection is the first of the three operations in which individual strings are copied according to their objective function or fitness and it is known as selection operator, as it selects good strings from a population and form a mating pool. The commonly used selection operator is the proportionate selection operator, where a string is selected for the mating pool with a probability proportional to its fitness. Tournament method approach is followed in selecting the mating pool.

From the mating pool and are altered in a manner such that some portions of the strings are exchanged between them as shown in figure (4) .

### **Results and Discussion**

A practical method is proposed for analysis of ethylene refrigeration system by using mathematical programming. A computer program was developed to simulate the operating conditions of an ethylene refrigeration system in the ethylene unit in Basrah petrochemical complex number 1 (PC1). The results of the model are compared with the design data obtained from the operating manuals of the (lummus company) for ethylene refrigeration cycle .The comparison gave very satisfactory results for the pressure and temperature for each node of the cycle. The results of comparison are listed in table (2).

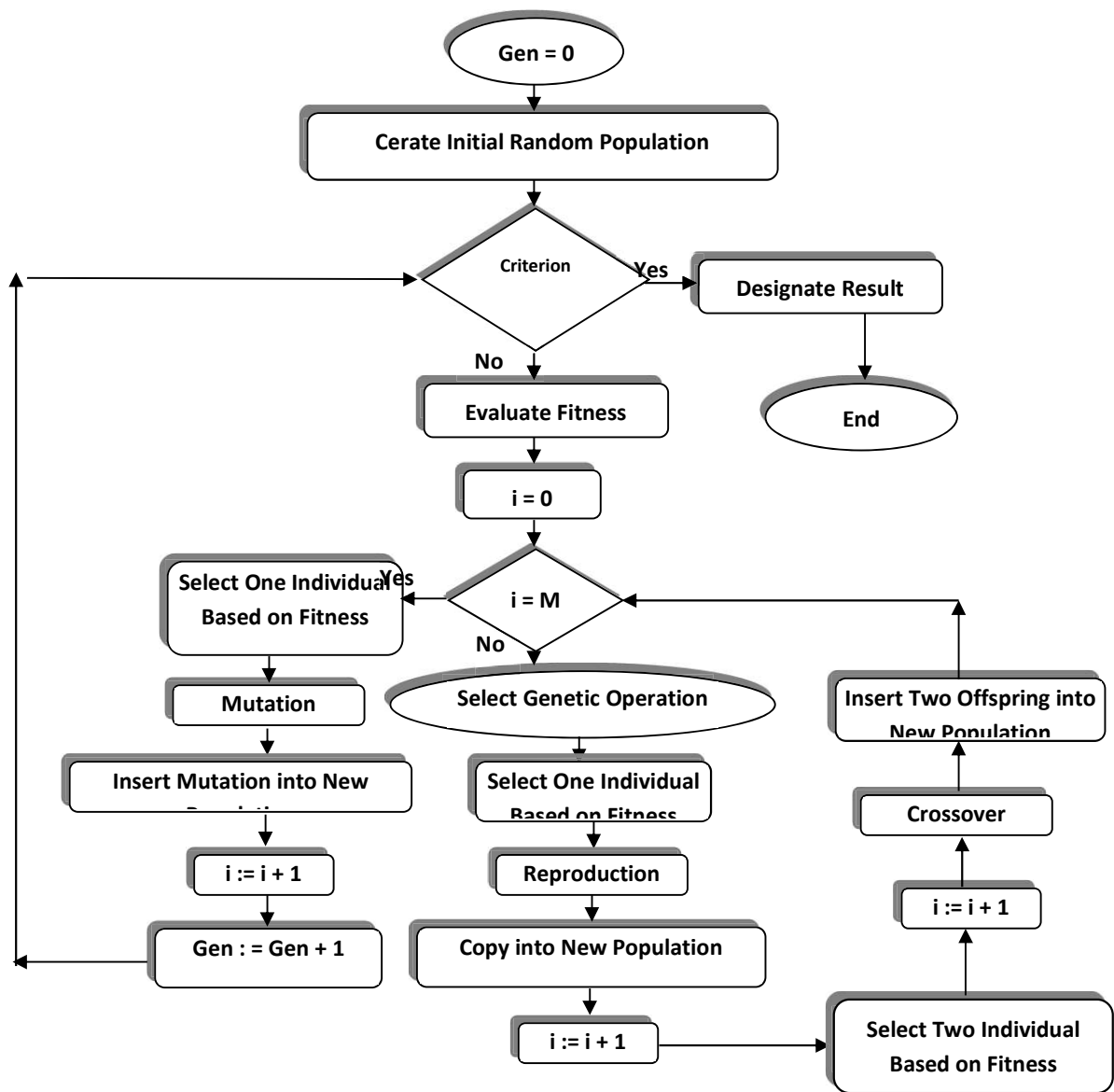


Fig.(4)Flow Chart of the Genetic Algorithm Method [13] .

**Table (2): Comparison between the Design Data (Manuel) for Ethylene Refrigeration System and the Simulation Results**

Node No.	Design (Manual)		Simulation	
	P(bar)	T(°C)	P(bar)	T(°C)
2	29.95	-13.7	29.95	-13.4
3	9	-55	9.08	-54.9
4	9	-55	9.08	-54.9
5	9	-55	9.08	-54.9
6	9	-55	9.08	-54.9
7	9	-55	9.08	-54.9
8	4.2	-75	4.21	-75.4
9	4.2	-75	4.21	-75.4
10	4.2	-75	4.21	-75.4
11	4.2	-75	4.21	-75.4
12	4.2	-75	4.21	-75.4
13	1.14	-101.4	1.14	-101.6
14	1.14	-101.4	1.14	-101.6
15	1.07	-84.7	1.07	-84.6
16	4.2	-2.5	4.21	-2.45
17	3.98	-69	3.99	-69.4
18	4.2	-36.4	4.21	-36.2
19	9	14.7	9.08	14.7
20	8.74	-52.2	8.79	-51.9

21	9	1	9.08	1.02
1	31.17	101	31.1	98.8
		<b>Design (Manual)</b>		<b>Simulation</b>
<b>Over all efficiency of system %</b>		<b>80.2</b>		<b>79.9</b>
<b>Energy saving %</b>		<b>39.7</b>		<b>39.4</b>

### **The Optimization Results**

The results of the optimization technique are shown in table (4.2). The results indicate that a maximum overall efficiency of the ethylene refrigeration cycle and the percentage energy saving may be obtained when the ethylene refrigeration cycle operate at (2.8) bar evaporator low pressure, (28.7) bar compressor discharge high pressure, (19)<sup>o</sup>C condenser degree of sub-cool temperature and (3.4)<sup>o</sup>C evaporator degree of super-heating temperature.

**Table (3): The Results of Optimization Technique**

The Operating Variables	The Optimization Result
Evaporator low pressure (bar)	2.8
Compressor discharge high pressure (bar)	28.7
Condenser degree of sub-cooling temperature (C <sup>o</sup> )	19
Evaporator degree of super-heating temperature (C <sup>o</sup> )	3.4
Overall efficiency	81.8
Percentage energy saving	51.18



**Effect of Evaporator Low Pressure ( $P_L$ )**

- The shaft work of the compressor decreased with increasing the evaporator low pressure as shown in figure (5), because the enthalpy of vapour inlet to compressor increased with increasing evaporator low pressure and it leads to decrease the enthalpy difference about the compressor. These results are in agreement with works of [14, 15].
- It is necessary to minimize shaft work in order to avoid excessive energy consumption and accurse the increase in percentage energy saving; this was applied by increasing evaporator low pressure as shown in figure (6).
- The effect of evaporator low pressure on the vapour fraction (refrigerant quality) is shown in figure (7), when the evaporator low pressure increase the refrigerant quality decrease for three levels of the ethylene refrigeration cycle; since it creates increasing in specific enthalpy in vaporisation i.e.( increasing evaporating latent heat ). These results are in agreement with works of [16].
- The effect of the increasing in evaporator low pressure on the total refrigeration effect of three levels of the ethylene refrigeration cycle is shown in figure (8). The increase in evaporator low pressure has a positive effect on the refrigeration capacity, since increasing evaporator low pressure will increase the specific enthalpy of vapour outlet from the evaporator and can be seen this statement on the Mollier chart for ethylene refrigerant.

Then the decrease in shaft work and the increase in the refrigeration effect as a result of increasing evaporator low pressure was noticeable by the increase in coefficient of performance of the ethylene refrigeration cycle thus lead to an increase in overall efficiency of the cycle by comparing actual coefficient of performance with ideal coefficient of performance, as shown in figure (9). It can be notice the effect of increasing evaporator low pressure at (1and 3) bar on the performance of the overall ethylene refrigeration cycle by drawing it on the Mollier (P-h) diagram, as shown in figure (10).

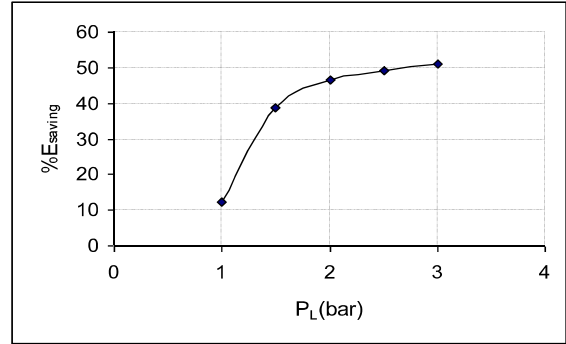
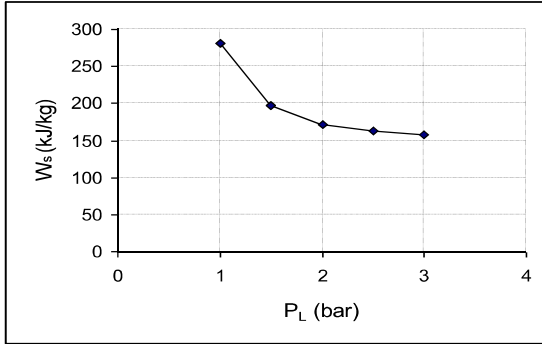


Fig.(6)Percentage energy saving(%E<sub>saving</sub>) vs. Evaporator low pressure (P<sub>L</sub>)

Fig.(5) Compressor shaft work (Ws) vs. Evaporator low pressure (P<sub>L</sub>)

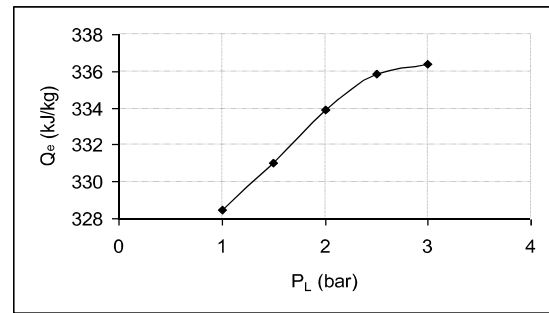
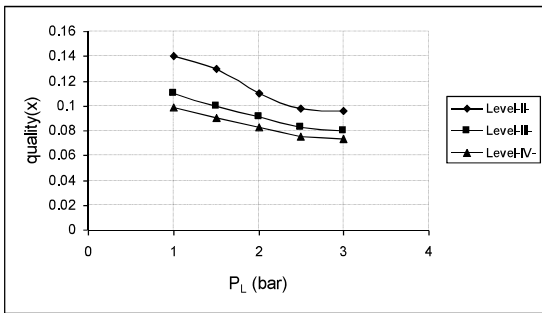


Fig.(7)Refrigerant quality(x) vs. Evaporator low pressure (PL)

Fig.(8) Refrigeration effect (Qe) vs. Evaporator low pressure (PL)

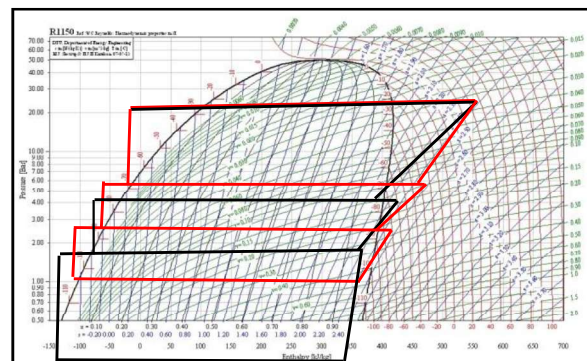
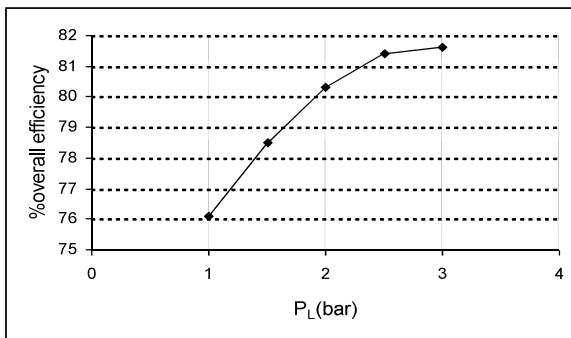


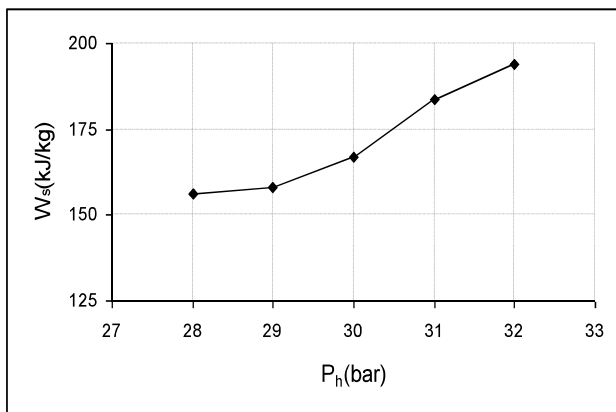
Fig.(9) Overall efficiency vs. Evaporator low pressure (PL)

Fig.(10) Performance of ethylene refrigeration system at different PL=1bar PL=3bar

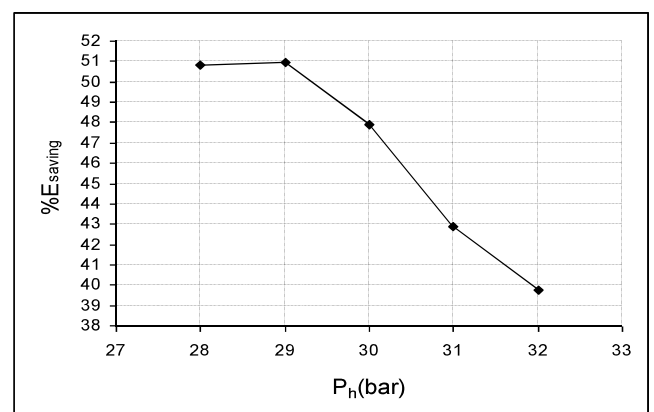
**Effect of Compressor Discharge High Pressure( $P_h$ )**

Figure (11) shows increase of shaft work from (156.35 to 193.78) (kJ/kg) when the compressor discharge pressure increases from 28 to 32 bar at optimum evaporator low pressure , evaporator degrees of super heat temperature and condenser degree of sub-cool temperature due to an increase in enthalpy difference about the compressor and figure (12) shows that percentage energy saving decreased as compressor discharge high pressure increased at optimum evaporator low pressure , evaporator degrees of super heat temperature and condenser degree of sub-cool temperature.

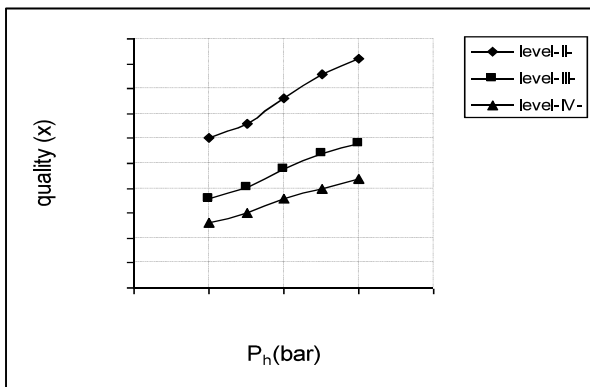
- Figure (13) shows the refrigerant vapor fraction increases for three levels of refrigeration cycle when compressor discharge pressure increase because increasing in flashing into expansion valve that leads to decrease latent heat [17,18].
- The decrease in refrigeration effect with increasing compressor discharge high pressure Is shown in figure (14). The variation in the coefficient of performance verses compressor discharge high pressure shown in figure (15).
- The key to overall efficiency of ethylene refrigeration cycle improvements by decreasing compressor discharge high pressure as shown in figure (16).



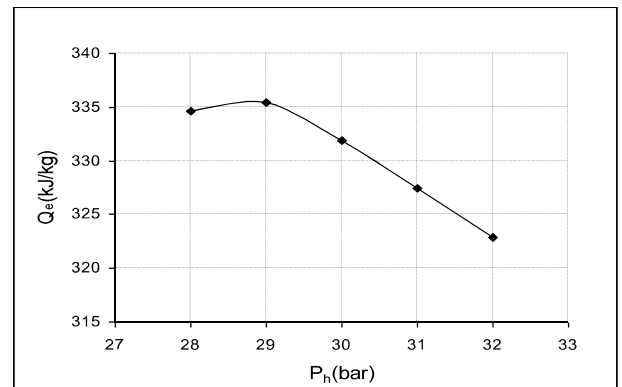
**Fig.(11) Compressor shaft work vs. Compressor discharge high pressure**



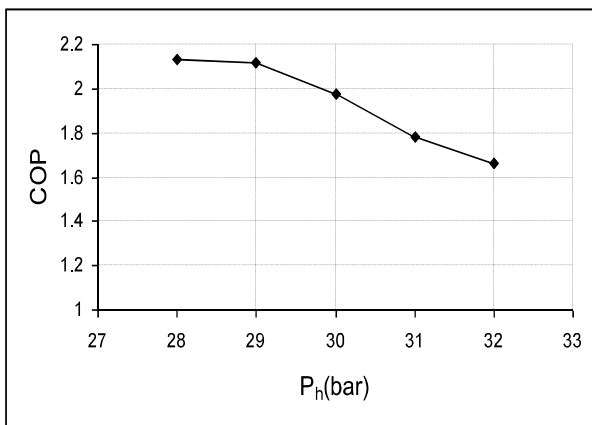
**Fig.(12)Percentage energy saving vs. Compressor discharge high pressure**



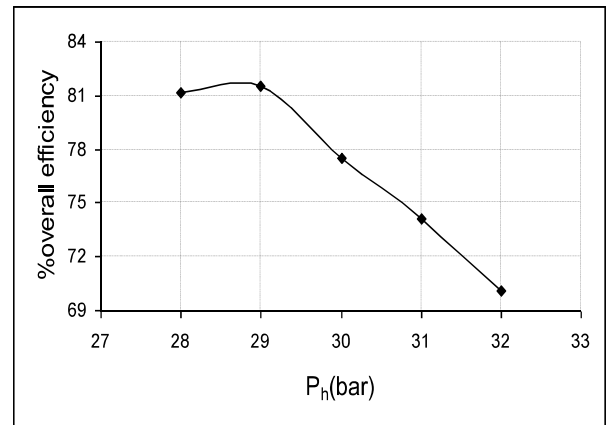
**Fig.(13) Refrigerant quality vs. compressor discharge high pressure**



**Fig.(14) Refrigeration effect vs. Compressor discharge high pressure**



**Fig.(15) Coefficient of performance vs. Compressor discharge high pressure**



**Fig.(16) Overall efficiency vs. Compressor discharge high pressure**

**Effect of Condenser Degree of SubCool Temperature ( $T_{sub-D}$ )**

- The increasing in the cooling water and propylene flow rate promotes sub-cooling in the condensers, this represents the temperature of the liquid (ethylene refrigerant) leaving the condenser is lower than saturated temperature. Any such increase in condenser degree of sub-cooling temperature

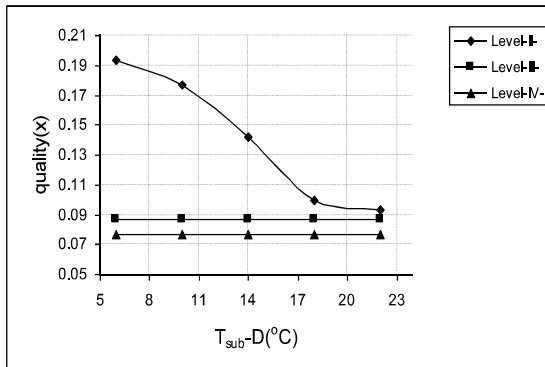
is at the expense only of additional secondary refrigerants such as cooling water [17].

- Figure (17) indicates an increase in condenser degree of sub-cooling temperature leads to decrease the refrigeration quality for the level (II) only of the ethylene refrigeration cycle, because the ethylene refrigerant entering the expansion valve at a lower temperature has a lower enthalpy. As this refrigerant expands to the evaporator low pressure, it has a lower quality. These results agreements with work of [16].

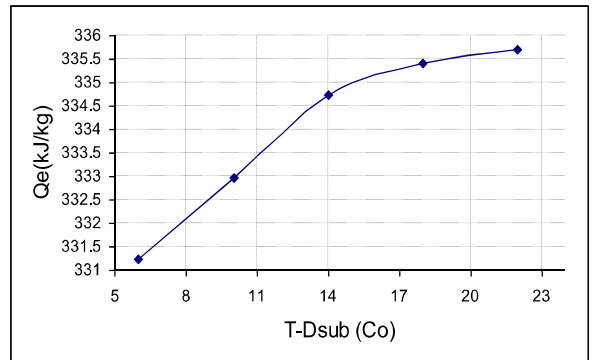
Increasing of condenser degree of sub-cooling temperature leads to an increase in the refrigeration effect into evaporators in the level (II) only of the ethylene refrigeration cycle as shown in figure (18).

- Figure (19) indicates that an increase in condenser degree of sub-cooling temperature has no effect on the shaft work of compressor then the percentage energy saving remained constant as condenser degree of sub-cooling temperature is increased, as shown in figure (20), because the compressor power requirements remain unchanged [17].

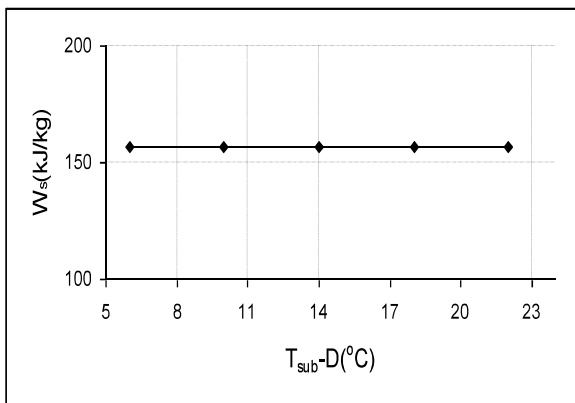
From figure (21) note that increased in condenser degree of sub-cooling temperature leads to an increase performance of the ethylene refrigeration cycle and to an increase overall efficiency of ethylene refrigeration cycle. The results of effect of condenser degree of sub-cooling temperature on the ethylene refrigeration cycle for ( $T_{sup-D}=\text{optimum}$ ,  $T_{sub-D}=6^{\circ}\text{C}$ ,  $P_L=\text{optimum value}$  and  $P_h=\text{optimum value}$ ) and of ( $T_{sup-D}=\text{optimum}$ ,  $T_{sub-D}=19^{\circ}\text{C}$ ,  $P_L=\text{optimum}$ , and  $P_h=\text{optimum}$ ,) is shown on a neatly drawn Mollier diagram figure (22).



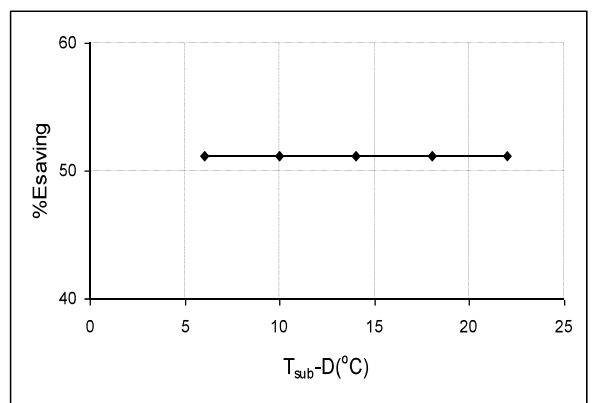
**Fig.(17) Quality(x) vs. Condenser degree of sub-cooling temperature**



**Fig.(18) Refrigeration effect vs. Condenser degree of sub-cooling temperature**



**Fig.(19) Shaft work vs. Condenser degree of sub-cooling temperature**



**Fig.(20) Percentage energy saving vs. Condenser degree of sub-cooling temperature**

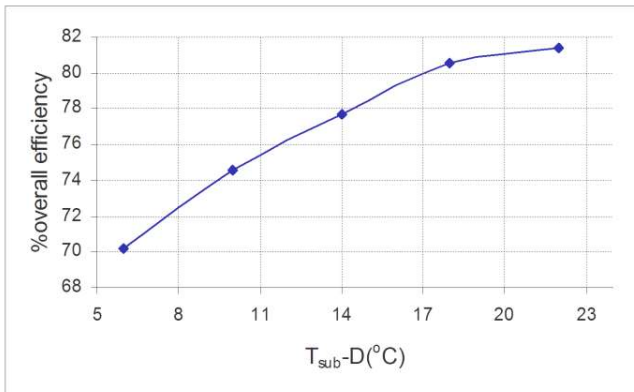


Fig. (21) Overall efficiency vs. Condenser degree of sub-cooling temperature

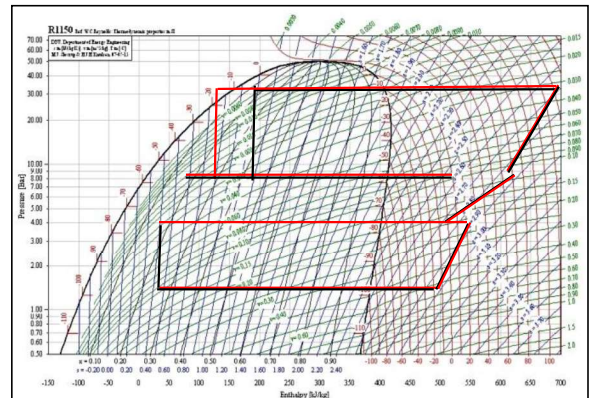
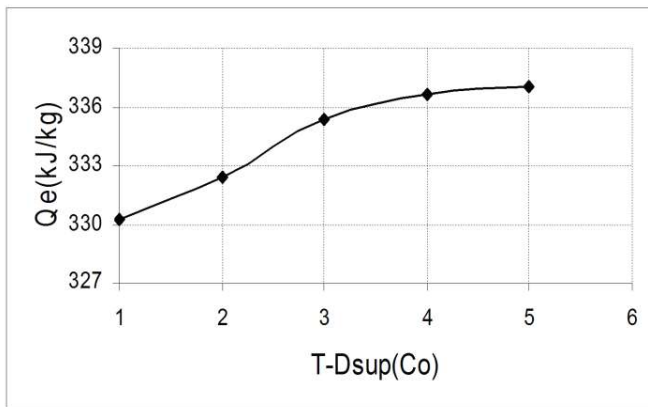


Fig. (22) Performance of ethylene refrigeration system at different condenser degree of sub cool temperature

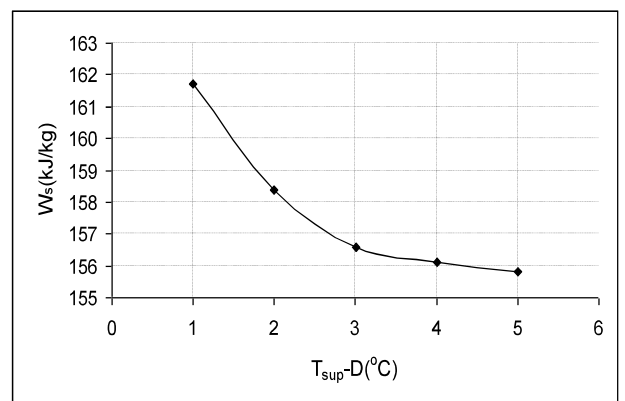
## Effect of Evaporator Degree of Superheat Temperature ( $T_{sup-D}$ )

The effect of evaporator degree of superheat temperature ( $T_{sup-D}$ ) on the performance of components of ethylene refrigeration cycle, overall efficiency of cycle and percentage of energy saving of ethylene refrigeration cycle also investigated for an optimum values of evaporator low pressure, compressor discharge high pressure and condenser degree of sub-cooling temperature, and the results are illustrated in figures (23) to (26). Figure (23) gives variation of the total refrigeration effect of three levels of cycle with evaporator degree of superheating temperature, the trend indicates an increase in the refrigeration effect as the degree of superheat temperature increased because a (kJ/kg) of refrigeration capacity have been added, these show an agreement with the work of (Stoecker and Jones) [19]. The results show an inversely relation between degree of superheat temperature and the shaft work of compressor, stating from (1 to 5) °C, this behaviour is shown in figure (24) and are in agreement with the results of (Domanski) [20]. Figure (25) shows that shaft work of centrifugal compressor is decreased when the degree of superheat temperature increase to

about (3 °C), then slightly decrease in shaft work .Therefore, a slight amount of superheat between the evaporator output and the compressor inlet, in order to ensure that no liquid enters the compressor. The increase in evaporator degree of superheat temperature caused an increase in refrigeration effect and decreases in shaft work that leads to an increase in overall efficiency of the cycle as shown in figure (25). Also figure (26) shows the relationship between percentage energy saving and evaporator degrees of super- heat. Percentage energy saving increase as evaporator degree of superheat temperature increase since the decreased in consumption for energy into the compressor that leads to increase the percentage energy saving of the ethylene refrigeration cycle.

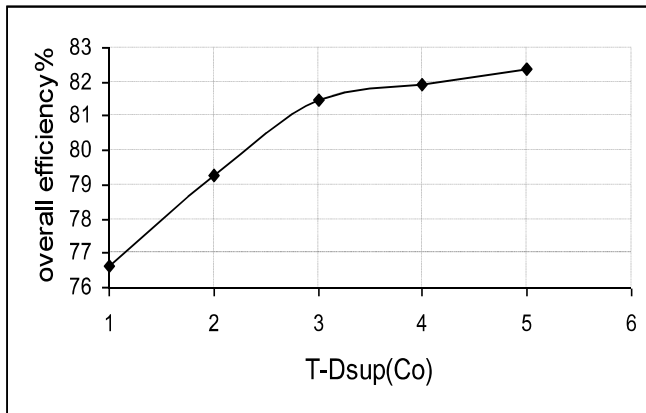


**Fig.(23) Refrigeration effect vs. Evaporator degree of super-heating temperature**

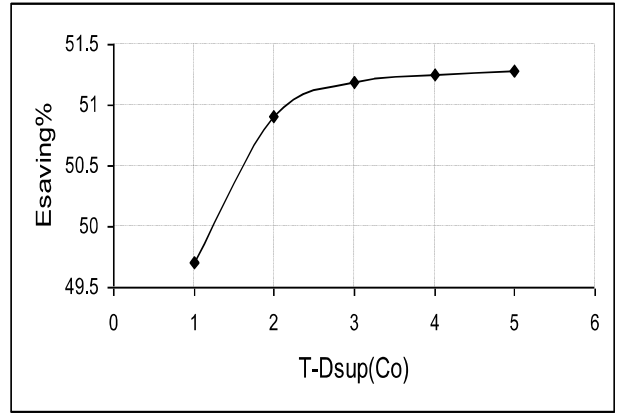


**Fig.(24) Shaft work vs. Evaporator degree of super-heating temperature**





**Fig.(25)%Overall efficiency vs. Evaporator degree of super-heating Temperature**



**Fig.(26)Percentage energy saving vs.Evaporator degree of super-heating temperature**

### Simulation Results for the Effect of Different Operating Variables on the Overall Efficiency of the System and the Percentage Energy Saving

The relationships between the operation variables (evaporator low pressure, compressor discharge high pressure, condenser degree of sub-cooling temperature and evaporator degree of superheat temperature ) and overall efficiency of the system and the percentage energy saving are plotted as shown in figures in (27 ) to (49 ). Each plot illustrates the variation of Overall Efficiency of the System and the percentage energy saving with two variables, the third and fourth was fixed at the optimum value.

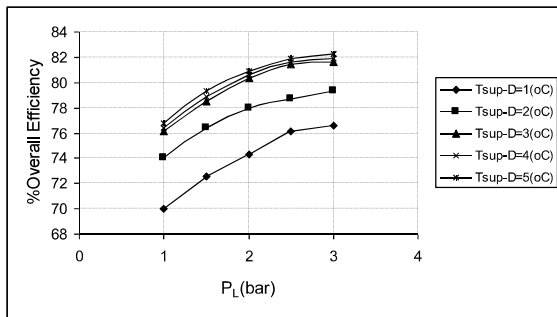


Fig.(27) Overall efficiency vs. evaporator low pressure at optimum compressor high pressure =28.7 bar, condenser degree of sub-cooling temperature=19oC and different evaporator degree of super-heating temperature.

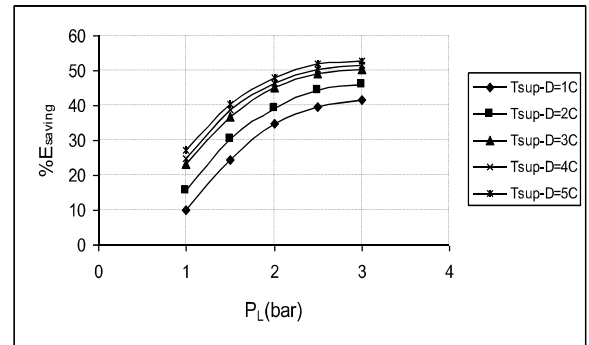


Fig.(28)Percentage energy saving vs. evaporator low pressure at compressor high pressure =28.7bar, condenser degree of sub-cooling temperature=19Co and different evaporator degree of super-heating temperature.

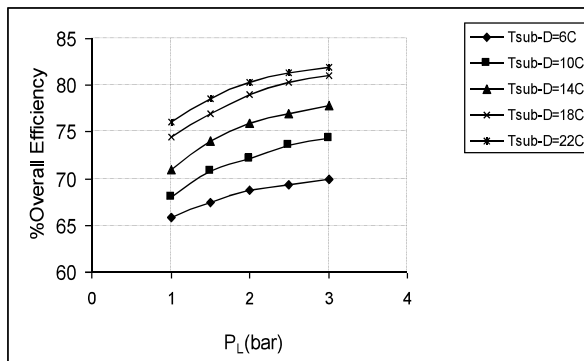


Fig.(29) Overall efficiency vs. evaporator low pressure at compressor high pressure =28.7bar, evaporator degree of super-heating temperature =3.4Co and different condenser degree of sub-cooling temperature.

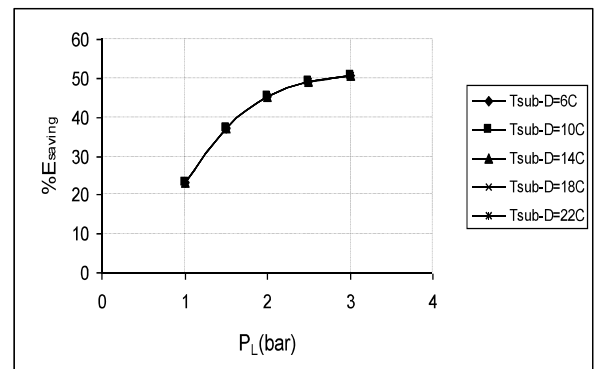
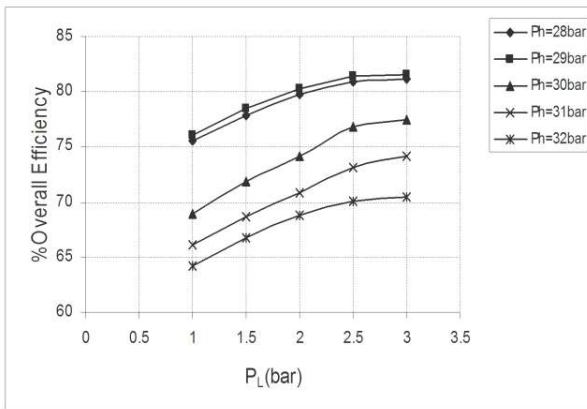
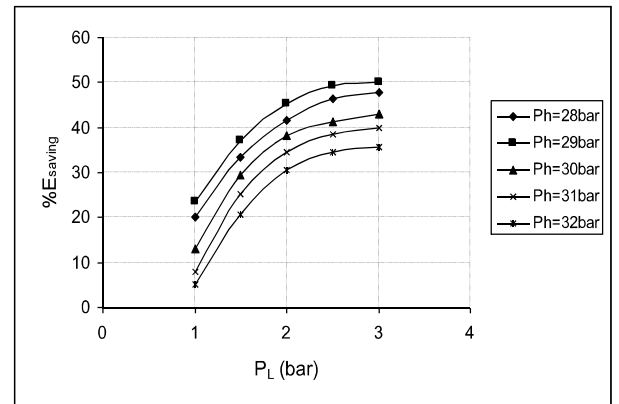


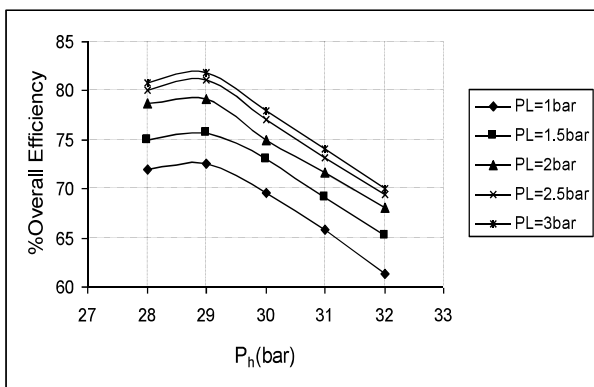
Fig.(30)Percentage energy saving vs. evaporator low pressure at compressor high pressure =28.7bar, evaporator degree of super-heating temperature =3.4 Co and different condenser degree of sub-cooling temperature.



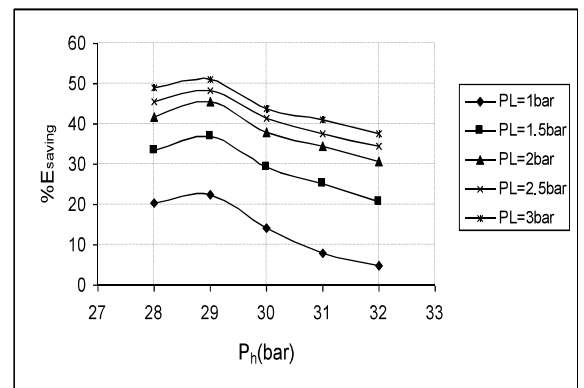
**Fig.(31) Overall efficiency vs. evaporator low pressure at evaporator degree of super-heating temperature =3.4Co, condenser degree of sub-cooling temperature=19Co and different compressor discharge high pressure**



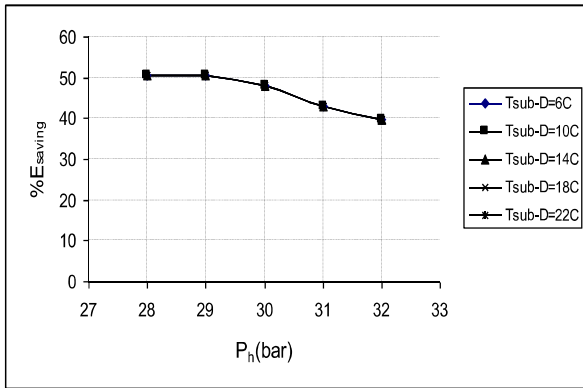
**Fig.(32) Percentage energy saving vs. evaporator low pressure at evaporator degree of super-heating temperature =3.4Co, condenser degree of sub-cooling temperature=19Co and different compressor discharge high pressure**



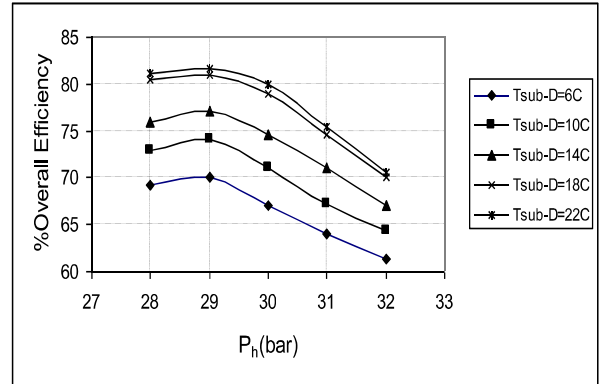
**Fig.(33) Overall efficiency vs. compressor discharge high pressure at condenser degree of sub-cooling temperature=19Co, evaporator degree of super-heating temperature =3.4Co and different evaporator low pressure.**



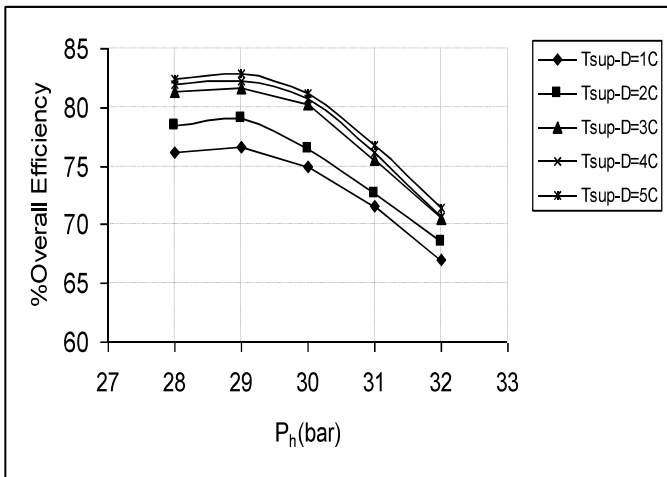
**Fig.(34) Percentage energy saving vs. compressor discharge high pressure at condenser degree of sub-cooling temperature=19Co, evaporator degree of super-heating temperature =3.4Co and different evaporator low pressure**



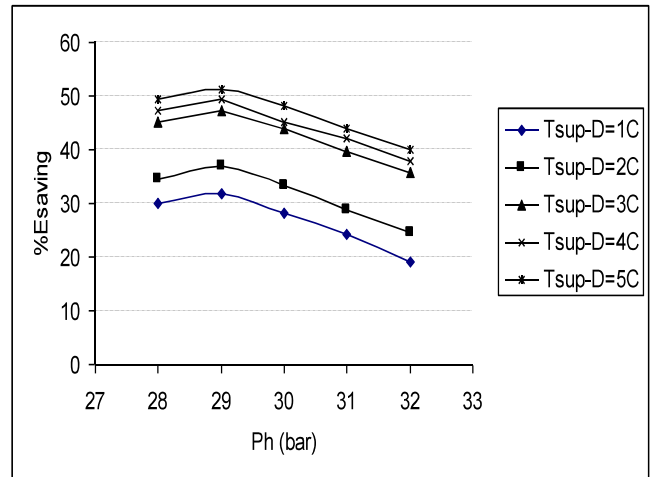
**Fig.(35) Overall efficiency vs. compressor discharge high pressure at evaporator low pressure=2.8 bar, evaporator degree of super-heating temperature =3.4Co and different condenser degree of sub-cooling temperature.**



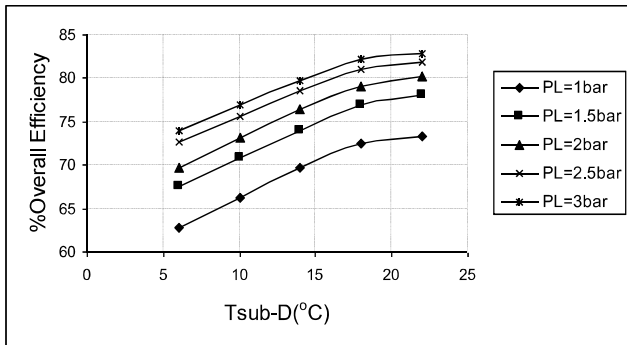
**Fig.(36) Percentage energy saving vs. compressor discharge high pressure at evaporator low pressure=2.8 bar, evaporator degree of super-heating temperature =3.4Co and different condenser degree of sub-cooling temperature.**



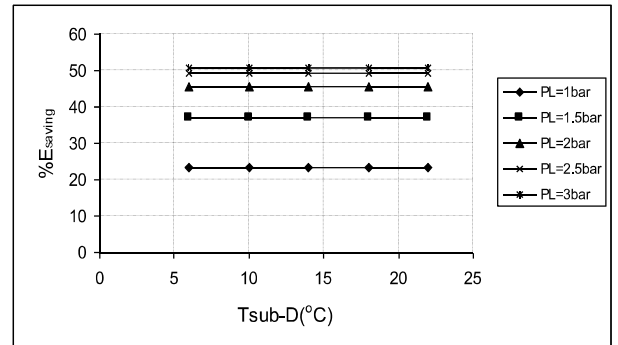
**Fig.(37) Overall efficiency vs. compressor discharge high pressure at evaporator low pressure=2.8 bar, condenser degree of sub-cooling temperature =19Co and different evaporator degree of super-heating temperature.**



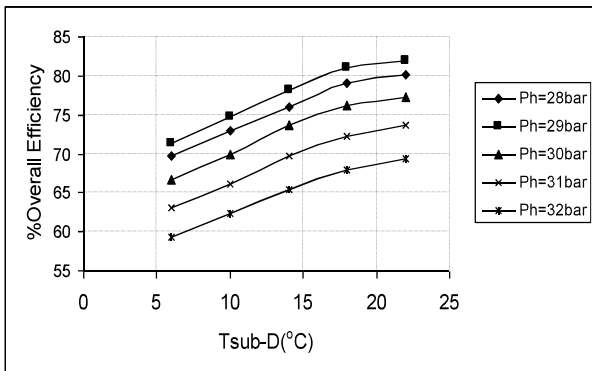
**Fig.(38) Percentage energy saving vs. compressor discharge high pressure at evaporator low pressure=2.8 bar, condenser degree of sub-cooling temperature =19Co and different evaporator degree of super-heating temperature.**



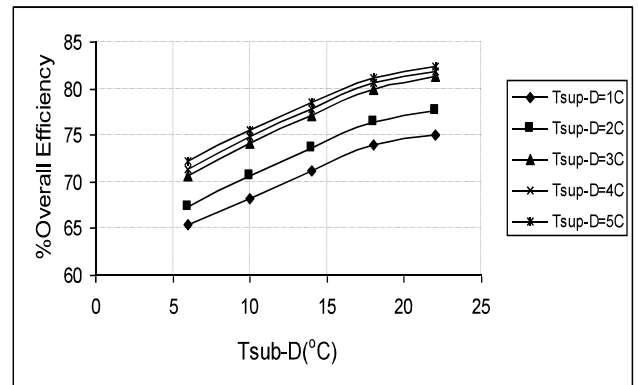
**Fig.(39) Overall efficiency vs. condenser degree of sub-cooling temperature at compressor discharge high pressure at =28.7 bar, evaporator degree of super-heating temperature=3.4 Co and different evaporator low pressure.**



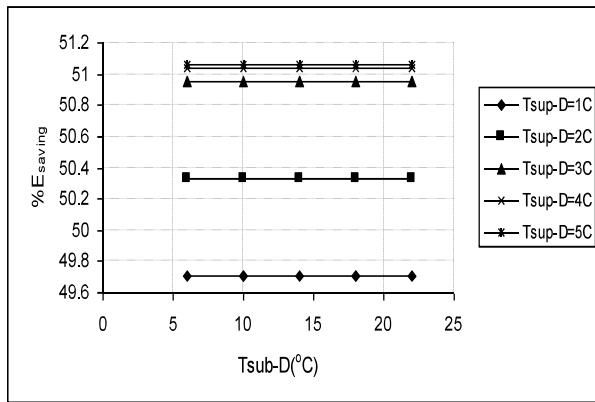
**Fig.(40) Percentage energy saving vs. condenser degree of sub-cooling temperature at compressor discharge high pressure at =28.7 bar, evaporator degree of super-heating temperature=3.4 Co and different evaporator low pressure.**



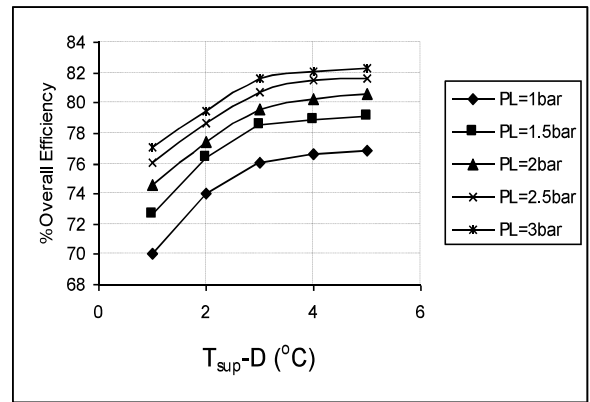
**Fig.(41) Percentage energy saving vs. condenser degree of sub-cooling temperature at evaporator low pressure= 2.8bar, evaporator degree of super-heating temperature=3.4 Co and different compressor discharge high pressure.**



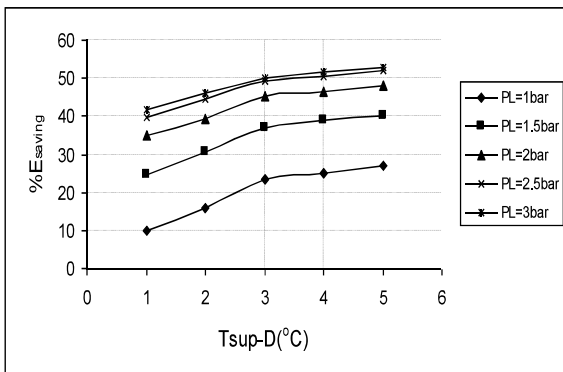
**Fig.(42) Overall efficiency vs. condenser degree of sub-cooling temperature evaporator low pressure= 2.8bar, compressor discharge high pressure =28.7bar and different evaporator degree of super-heating temperature.**



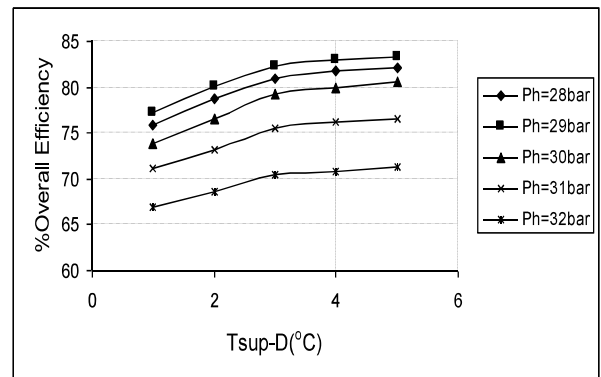
**Fig.(43) Percentage energy saving vs. condenser degree of sub-cooling temperature at evaporator low pressure= 2.8bar, compressor discharge high pressure =28.7bar and different evaporator degree of super-heating temperature.**



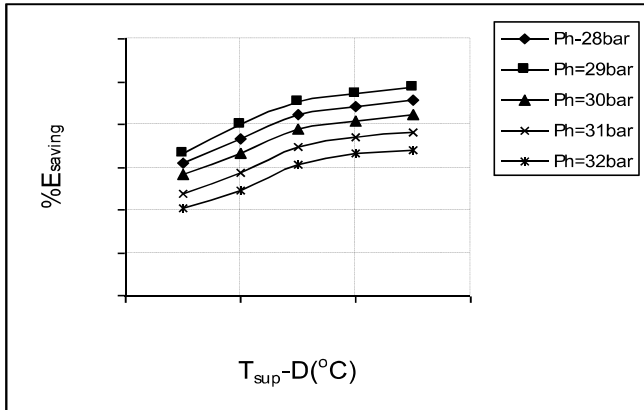
**Fig.(44) Overall efficiency vs. evaporator degree of super-heating temperature at condenser degree of sub-cooling temperature =19Co, compressor discharge high pressure= 28.7bar and different evaporator low pressure.**



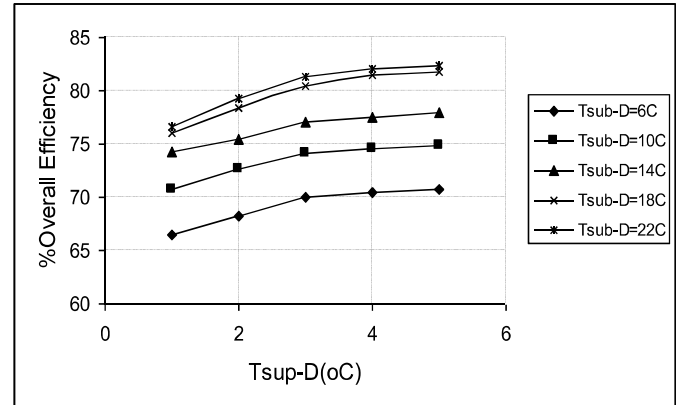
**Fig.(45)Percentage energy saving vs. evaporator degree of super-heating temperature at condenser degree of sub-cooling temperature =19Co, compressor discharge high pressure= 28.7bar and different evaporator low pressure.**



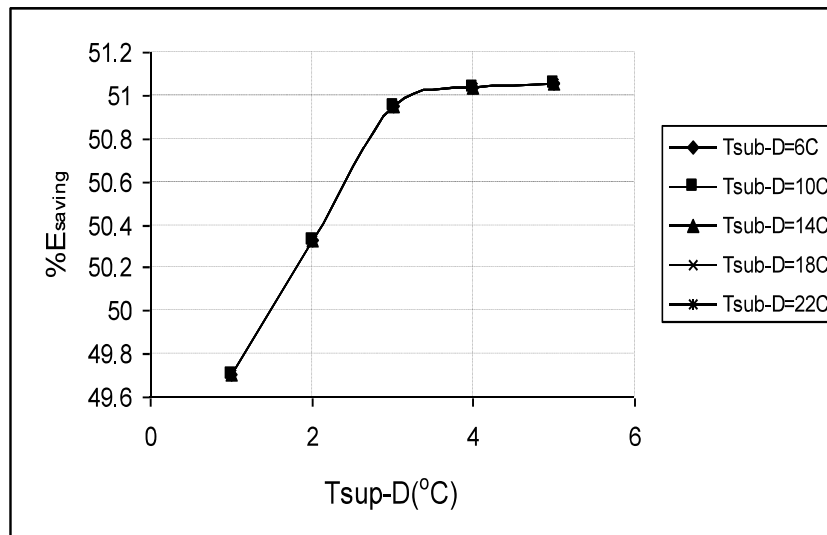
**Fig.(46) Overall efficiency vs. evaporator degree of super-heating temperature at condenser degree of sub-cooling temperature =19Co, evaporator low pressure= 2.8bar and different compressor discharge high pressure.**



**Fig.(47)Percentage energy saving vs. evaporator degree of super- heating temperature at condenser degree of sub-cooling temperature =19Co evaporator low pressure= 2.8bar and different compressor discharge high pressure.**



**Fig.(48)Overall efficiency vs. evaporator degree of super-heating ttemperature at compressor discharge high pressure=28.7bar , evaporator low pressure= 2.8bar and different condenser degree of sub-cooling temperature**



**Fig.(49) Percentage energy saving vs. evaporator degree of super- heating temperature at compressor discharge high pressure=28.7bar, evaporator low pressure= 2.8bar and different condenser degree of sub-cooling temperature.**

## Conclusions

Large amount of energy is used every year in ethylene refrigeration system . So, finding the optimum operating conditions for saving this energy is important, since saving energy means saving cost. This refrigeration system is incorporated with another refrigeration system serving other parts of the plant; therefore, any reduction in the refrigeration load will affect not only the economics of the ethylene refrigeration closed loop cycle but also the entire ethylene plant. By applying various stated variables the following is concluded from the obtained results:

1. It is undesirable to operate with high vapor fraction at input to evaporator, as it will lead to inefficient absorption of heat from the process gases. High vapor fraction leads to low refrigeration load. The low refrigeration effect ( $Q_e$ ) is an indicator of performance of refrigeration in efficiency.
2. The adoption of evaporator degree of superheat temperature ( $T_{sup-D}$ ) in the design of the evaporators is more efficient because of the reduction of shaft-work of the centrifugal compressor. In addition can be considered as safety factor in the design to avoid the detrimental of the compressor. It was found that the optimum value is (3.4°C) in the range of (1-5) °C.
3. The effect of condenser degree of sub-cooling temperature ( $T_{sub-D}$ ) on the refrigeration capacity shows that the evaporators is more efficient when the condensers are cooled down. This is right especially for high condenser degree of sub-cool temperature for a specific range (6-22) °C, where the refrigerant stream temperature outlet from condenser decreases is larger, and condensing process a more significant effect on the evaporators in heat absorbed from process gases.
4. Evaporator low pressure ( $P_L$ ) and compressor discharge high pressure ( $P_h$ ) effect on the ethylene refrigeration system show that the refrigeration process is more efficient when it works at lower ( $P_h$ ) and higher ( $P_L$ ) for a specific range.
5. The overall efficiency of the ethylene refrigeration system increases when:



Increasing evaporator low pressure, decreasing compressor discharge high pressure, increasing evaporator degree of superheat temperature to about 3.4 °C, then it had no significant effect with further increasing of evaporator degree of superheat temperature and increasing with condenser degree of sub-cool temperature up to 19 °C.

6. The percentage energy saving for ethylene refrigeration system increases when:

Increasing evaporator low pressure, decreasing compressor discharge high pressure, increasing evaporator degree of superheat temperature to about 3.4 °C . But the increasing with condenser degree of sub-cool temperature doesn't effect on the percentage energy saving.

7. The optimum operating conditions for the ethylene refrigeration system are 2.8bar evaporator low pressure, 28.7bar compressor discharge high pressure, 3.4 °C evaporator degree of superheat temperature and 19 °C condenser degree of sub-cool temperature, which gave a maximum overall efficiency of 81.8% and percentage energy saving of 51.18% .

## References

1. George G., "Inspection of chemical plant", pg.54, Mc Grew-Hill , New Yourk , (1993).
2. Hsuan C. ,Jia J., "Heat exchange network design for an ethylene process using dual temperature approach", Journal of science and engineering, vol.8, pg.283-290,(2005).
3. Lee G., "Synthesis of refrigeration systems by shaft work targeting and mathematical optimization", Ph.D. thesis, Florence, Italy, May, (2005).
4. Mohapatra S.," Selecting a heat transfer fluids for low temperature applications", Process cooling and equipment, April, pg. 1-5, (2000).
5. ASHRAE, "Refrigerants", ASHRAE Handbook fundamentals, chapter 19, pg.244,(1997).
6. Linnhoff B.; Toensend D.; Boland D.;Thomas B.," A user guid on process integration for the efficient use of energy", The institute of chemical engineers, March,(1991).
7. Lummus company, "Operating manual for Basrah petrochemical complex number 1", copy 1, part 1, pg.11A.,(1973).
8. Marcello P., "Design for ethylene plant safety", Hydrocarbon processing , March , part I, (1978).
9. Marcel D., "Ethylene refrigeration systems power and condenser duty", Encyclopedia of chemical processing and design, Meketta, Editor vol.20,pg. 353, (1984).
10. Richard S.;Cheng W.; Mah H.,"Trane centrifugal chiller operating cycle", American chemical society, August, pg.420 ,(2003).
11. Simon L.,"Process control and optimization of an ethylene production", American institute of chemical engineers, March ,(2000).
12. Mitchell M.,"An introduction to genetic algorithm", 7<sup>th</sup> printing, Cambridge, Massachusetts, London, England, pg. 148-153, (2001).

## **No.13 Journal of Petroleum Research & Studies (JPR&S)**

13. Goldberd D., "Genetic in search, optimization and machine learning", Wesley Radiy, pg. 10-15, (19890).
14. Boiarski M.; Boris V.; Ralph C., " High efficiency cryogenic refrigerator based on one stage compressor", U.S.A. Patent, 5706663, January,13, (2004).
15. Edward G.,"Refrigeration principles and system", Business news publishing company, December,(1991).
16. Hosoz M.;Kilicarslan A. "Performance evaluations of refrigeration system with air-cooled, water cooled and evaporative condensers", International journal of energy research, vol.28, May, (2004).
17. Richard C.; Gayle B.; "Refrigeration and air conditioning", 2<sup>nd</sup> edition, Prentice-Hall of India private limited, New Delhi, August, (1973).
18. Brokowski M., " Design of the vapor compression refrigeration cycles", Cycle pad library-analysis of engineering cycles, Northwestern University,December,(2001).
19. Stoecker W.; Jones J.,"Refrigeration and air conditioning", 2<sup>nd</sup> edition,pg.284,McGraw-Hill,NewYork,(1989).
20. Domanski A.,"Theoretical evaluation of the vapor compression cycle with liquid-line/suction line heat exchanger, economizer and ejector",National Institute of Standards and Technology,(NIST), March, (1995).

**Nomenclatures:**

<b>Symbols</b>	<b>Definition</b>	<b>Units</b>
$COP$	Coefficient of performance	-
$m$	Mass flow rate	kg/s
$P$	Pressure	bar
$Q_{comp}$	Specific compression capacity	kJ/kg
$Q_e$	Specific refrigeration capacity	kJ/kg
$x$	Flash gas quality	-
$\eta$	Efficiency	-
$FE$	factory energy required refrigeration cycle	MW
$T_{sub-D}$	The condenser – degree of subcooling temperature	$^{\circ}C$
$T_{sup-D}$	The evaporator–degree of superheating temperature	$^{\circ}C$

**Subscripts**

<b>Symbols</b>	<b>Definition</b>
$comp$	Compressor
$cons$	Consumption
$e$	evaporator
$Eco$	Economizer
$H$	High pressure

## **No.13 Journal of Petroleum Research & Studies (JPR&S)**

<i>int</i>	Intermediate
<i>L</i>	Low pressure
<i>l</i>	liquid
<i>ASHRAE</i>	American society for heating, refrigeration and air conditioning engineering
<i>HEN</i>	Heat exchanger net work