



Flow of cement slurry through an eccentric annulus

Riayde Hussein Jawad

Iraqi Drilling Company

Corresponding Author E-mail: superintendentidc32@gmail.com

Abstract

A step by step procedure has been developed to design cement hydraulic during cement job to minimize non cemented channels or bad cement job by taking into consideration the non-flow area throughout the eccentric annulus. Since cement slurry exhibit non-Newtonian rheological behavior, a good description of the slurry rheology is required in order to estimate accurately the velocity profile across the annulus. To achieve this goal, six rheological models have been adopted: Power-law, Robertson-Stiff, Bingham, Casson, Modified Power-law, and Modified Robertson-Stiff Models. Using the last five rheological models, new frictional pressure gradient equations for laminar flow of cement slurry through an eccentric annulus have been derived by the author based on slit-approach approximation.

Key words: Cement slurry, Eccentric annulus, fluid flow.

الخلاصة:

لقد تم تطوير الطريقة خطوة بخطوة لتصميم البرنامج الهيدروليكي للأسمنت أثناء عمليات التسميت لتجنب تكون القنوات الخالية من الأسمنت خلف البطانة وبالتالي الحصول على عملية تسميت ناجحة، وطريقة التصميم هذه تأخذ بعين الاعتبار المنطقة الضيقة التي لا يحدث فيها الجريان خلال مساحة مقطع الفراغ الحلقي. بما أن معجون الأسمنت يُظهر سلوكاً ريولوجياً غير نيوتونياً، لذلك يلزم وجود وصف جيد لريولوجيا المعجون من أجل الحصول على حساب دقيق لمقدار السرعة عبر الحلقة. ولتحقيق هذا الهدف، تم تبني ستة نماذج ريولوجية وهي:

Power-law, Robertson-Stiff, Bingham, Casson, Modified Power-law, and Modified Robertson-Stiff Models.

باستخدام آخر خمسة نماذج ريولوجية، تم اشتقاق معادلات جديدة لحساب تدرج الضغط الاحتكاكي للتدفق الصفيحي للسوائل غير النيوتونية من خلال الفراغ الحلقي غير المتمركز باستخدام فرضية الشق متغير الارتفاع لتمثيل الفراغ الحلقي غير المتمركز.

Introduction:

For all oil or gas wells, there can be three or more casing namely surface, intermediate, and production casing running into the well during the progress of drilling to reach the target reservoir. Each casing should be cemented base on specific cement program to get well bore support and perfect zonal isolation to avoid down hole blowout i.e. fluid flow from one permeable zone to another. After the casing reach to its setting depth, a series of fluid will be pumped inside casing and coming back to the annulus during cement operation. Typically, a spacer fluid is pumped first followed by one or more cement slurries followed by drilling mud to displace final cement slurry, the circulation stopped leaving few meters of cement inside the bottom of the casing.

If the mud in the annulus did not completely displaced by cement slurry, due to the presence of casing hole eccentricity, this may lead in most cases to create a continuous unconsolidated mud channels which may not allow perfect zone isolation.

Base on the graphical relationship between shear stress (τ) on y-axes and shear rate ($\dot{\gamma}$) on x-axes, fluid can be divided into two categories as Newtonian and non-Newtonian fluids. This (τ - $\dot{\gamma}$) relationship is defined as flow curve or rheogram of fluid.

The rheogram of Newtonian fluid will be straight line passing through the origin , the slop of this line is equal to constant viscosity, otherwise the fluid will be consider as Non-Newtonian fluids, till now there is no single equation can describe exactly the flow curve of all such fluids. Non-Newtonian fluids can be subdivided into two groups; time independent and time dependent fluids.

For time independent fluids, shear stress is depend only on the shear rate during isothermal flow, there are two types of this of fluid which are fluid with a yield stress and fluid without yield stress.

For fluid with a yield stress, the flow will not start before shear stress applied exceeding yield stress, which is equal to the intercept with y-axes on Cartesian co-ordinates, the rheogram of this type of fluid will be straight line or curve intersecting the shear stress axes at yield stress, while for fluid without yield stress, the flow occur immediately after applying any shear stress regardless on its value, the flow curve of this type of fluid can be represented by curve passing through origin on Cartesian co-ordinate.

The Non-Newtonian fluid in which the shear stress is a function of the value of shear rate and its duration and the past history of the fluid called Time dependent fluid which can be subdivide into ,Thixotropic fluids and Rheopectic fluids, depending on the shape of the shear stress –shear rate curve.

The equation used to approximate the relationship between shear stress and shear rate called rheological models such as; Bingham, Power-law, Casson, Robertson Stiff, Modified Power-law, Modified Robertson-Stiff, Ellis, Meter, Eyring, Powell-Ering, Seely, Growley-Kitzes, Dhaven, Prandtl-Eyring, Reiner-Philippoff, Sisko, and Sutter by models [9].For each fluid we should determine which of these rheological model approximates its flow curve by calculating AAPE for the adopted models, the one that gives the lowest AAPE will be selected as the best represent the flow curve of that fluid.

Literature review:

The problem of Non-Newtonian fluid flow through an eccentric annulus has been investigated by different authors started at 1965 by Vaudgn [16], they used the following approaches to solve this problem:

- 1-Consider eccentric annulus as the slit of variable height [4, 15, 16].
- 2-Used bipolar co-ordinate system [2, 6].
- 3-Simulate the eccentric annulus by infinite number of concentric annuli with variable outer radii [5].
- 4- Used numerical fluid-flow approach [1, 7, 12, and 14].

The difference among these approaches are the complexity of the calculations and accuracy of the results, slit of variable height approach is the most commonly used in the field industry because of its simplicity and acceptable accuracy of the results as compare with the other approaches.

Difinitions Of Eccentric Annulus parameters:

Eccentric annulus is defined as the annulus formed by two cylinders their centers are not located on same point as in case of concentric annulus. Offset (e); is the distance between inner and outer cylinder centers ,while concentric annular clearance can be defined as the inner radius of outer cylinder minus the outer radius of inner cylinder ($c = r_o - r_i$), the ratio between these two radii called radius ratio ($r^* = r_i / r_o$), finally, eccentricity can be defined as the ratio of the offset to the concentric annular clearance, it is dimensionless number as $\epsilon = e / c$ or in term of percent eccentricity as $\epsilon = 100 e / c$. Its value ranging from 0 i.e. concentric annulus to 1 or 100% in which the wall of inner cylinder will touch the outer cylinder in specific point. Figure (1) illustrates three values of eccentricity [9].

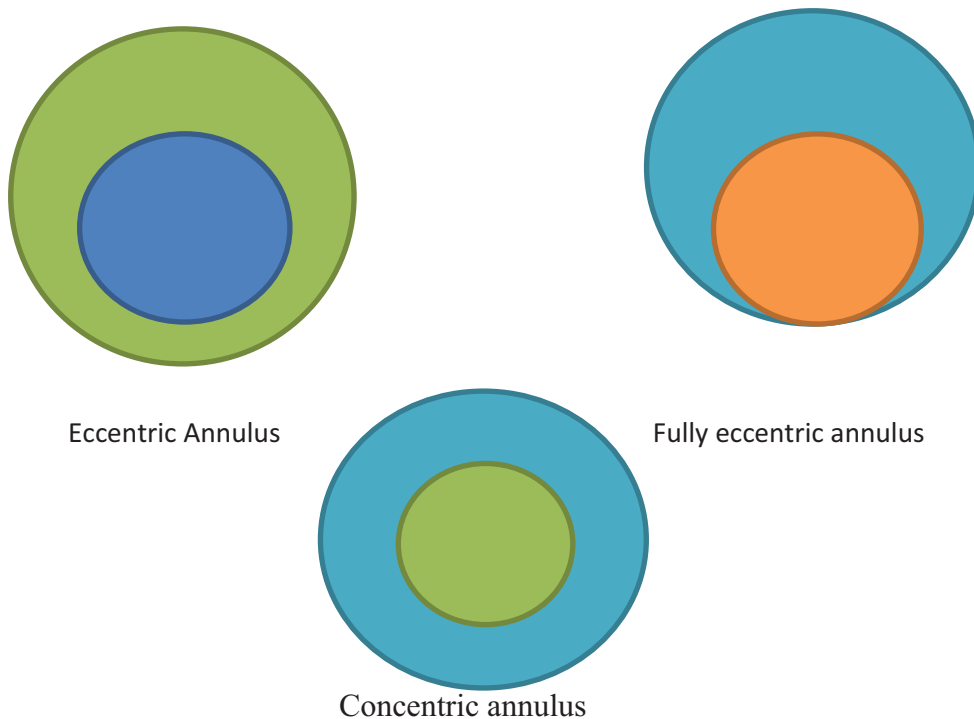

Fig. (1) Parameters of annular eccentricity (plan view) [9]

The problem of laminar flow through an eccentric annulus:

There are different approaches have been presented in the literatures [4, 5, 12, 14] to solve the problem of axial laminar flow through an eccentric annulus. The difference among them is related to the complexity of the method and accuracy of the results.

The slit approach will be adopted essentially because it is more appropriate for field application due to the simplicity of this approach and its accuracy as compare with the other approaches.

Assumptions Used to Derive flow equations:

Base on slit approach [4, 10, and 15]. A slit of variable height as illustrated in Figures (2&3) can be used to simulate eccentric annulus geometry. The following assumptions will be used to derive flow equations;

- 1- Non-Newtonian, time-independent, incompressible fluid.
- 2- One dimensional, steady state, isothermal, axial laminar flow.
- 3- Fluid velocity at the eccentric annulus walls equal to zero.
- 4- Velocity profile is symmetrical in both halves of the annulus.
- 5- The value of angle β is equal to 0° correspond to wide portion of the annulus, and equal to π correspond to the narrow cap of the annulus ,the slit height as derived by Iyoho [4] is given by;

$$h = r_o [\sqrt{1 - M^2 \sin^2(\beta)} + M \cos(\beta) - r^*] \dots \dots \dots (1)$$

Where; $M = \epsilon (1 - r^*)$

The governing differential equation for laminar flow through slit of variable height shown in Figure (3) can be written as [4, 9, 10];

$$\frac{\partial \tau}{\partial y} + \frac{\partial P}{\partial L} = 0 \dots \dots \dots (2)$$

IF the fluid is incompressible, the equation form can be written in this way:

$$\frac{\partial P}{\partial L} = \text{constant} = \frac{\Delta P}{\Delta L} = -g_{Pe}$$

Where; g_{pe} , is frictional pressure gradient only. Therefore,

$$\frac{\partial \tau}{\partial y} = g_{pe} \dots \dots \dots (3)$$

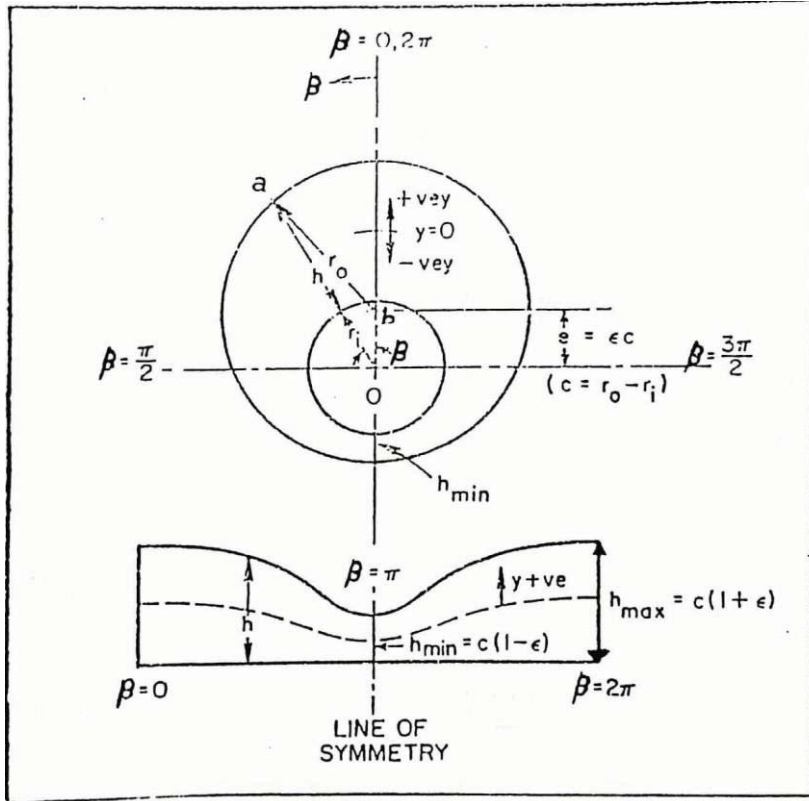

Fig. (2) Nomenclature for eccentric annulus & equivalent slit.

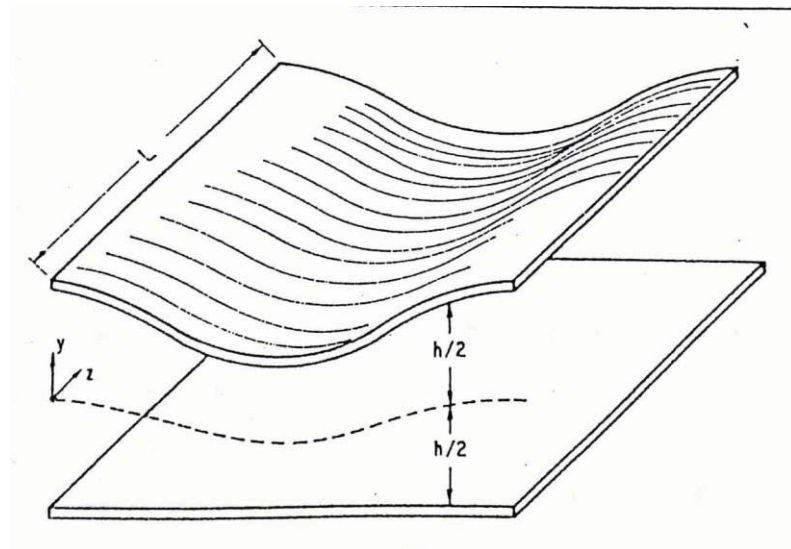

Fig. (3) Geometry for a slit of variable height.

Integrating Eq.3 with boundary condition of $\tau = 0$ at $y = 0$ to get;

$$\tau = y g_{Pe} \dots \dots \dots (4)$$

Eq. 4 determine shear stress values across the eccentric annulus, and

$$\gamma = \pm \frac{dv}{dy} \dots \dots \dots (5)$$

Eq. 5 determines shear rate values across the eccentric annulus. As shown in Figure (3), the positive sign of Eq 5 is for lower part of the slit, while the negative sign is for the upper part of the slit. The final equations relating pressure gradient with flow rate for laminar flow of non-Newtonian flow through an eccentric annulus for the adopted rheological models will be presented here, the derivation of these equations available with author.

1- Using rheological models without yield stress:

A-Using Power-law model; This equation derived by Uner et.al [15] in dimensionless form, and re-arranged to be in the field units as;

$$g_{Pe} = \frac{K}{600 r_o} \left[0.4 V_m (2 E_2 - \pi r^*) \frac{(s+2)}{J r_o} \right]^n \dots \dots \dots (6)$$

Where;

$$s = \frac{1}{n}$$

$$J = \int_0^\pi \left(\frac{h}{r_o} \right)^{s+2} d\beta = \int_0^\pi \left[\sqrt{1 - M^2 \sin^2(\beta)} + M \cos \beta - r^* \right]^{s+2} d\beta \dots \dots \dots (7)$$

$$E_2 = \int_0^{\pi/2} \sqrt{1 - M^2 \sin^2(\beta)} d\beta \dots \dots \dots (8)$$

The method of calculating integrals J and E_2 is presented at the end of this section.

B-Using Robertson-Stiff model; this model was taken from the following form [9];

$$\tau = A(\gamma + C)^B \dots \dots \dots (9)$$

The derivation of flow equation using this model is not presented here which can be formed as follows:

$$g_{Pe} = \frac{A}{600 r_o} \left[\frac{1+2B}{B J_1} \left(\frac{0.4 V_m (2E_2 - \pi r^*)}{r_o} + \frac{C}{2} H_1 \right) \right]^B \dots \dots \dots (10)$$

Where:

$$J_1 = \int_0^\pi \left(\frac{h}{r_o}\right)^{\frac{1+2B}{B}} d\beta = \int_0^\pi [\sqrt{1 - M^2 \sin^2(\beta)} + M \cos \beta - r^*]^{\frac{1+2B}{B}} d\beta \dots\dots\dots(11)$$

$$H_1 = \pi(1 + r^{*2}) - 4E_2r^* \dots\dots\dots(12)$$

The method of calculating integrals J_1 & H_1 is presented in the next section.

2- Using rheological models with yield stress;

A- Using Bingham Model;

This model takes the following form;

$$\tau = \tau_y + \mu_p \gamma \quad \text{for} \quad y_o < y \leq \frac{h}{2} \dots\dots\dots(13a)$$

$$\gamma = \frac{dv}{ay} = 0 \quad \text{for} \quad 0 < y \leq y_o \dots\dots\dots (13b)$$

Fluid with a yield stress will exhibited two types of flow in an eccentric annulus while shear stress applied increasing from zero to a certain maximum value, plug flow in the central core of the annular gap of the annulus and viscous flow in the annular space between the central core and the wall of the annulus .The width of plug flow regime can be obtained by substituting; $\tau = \tau_y$ at $y = y_o$ into equation (4) to get;

$$y_o = \tau_y / g_{pe} \dots\dots\dots (14)$$

Where, (y_o) represents a half width of the plug flow region.

In case of laminar flow for fluid with a yield stress, the flow through an eccentric annulus will not start over entire eccentric annulus. The flow starts in the wider gap portions after the pressure gradient exceed certain value, then the flow will spread toward the narrow gap portions of the annulus during gradual increasing of the pressure gradient until certain value of pressure gradient has been reached. Then the flow will occur over the entire cross-sectional area of an eccentric annulus. The following equations have presented here to explain the above phenomena, where the maximum annular clearance $h_{max.} = h_{at \beta=0}$ and minimum annular clearance $h_{min.} = h_{at \beta=\pi}$ are given below;

$$h_{max.} = c + e \quad \text{and} \quad h_{min.} = c - e \dots\dots\dots (15)$$

Substitute, $y_o = h_{max.}/2$ and $y_o = h_{min.}/2$ into equation (14) and substitute equation (15) into resulting equation to get;

$$g_{Pmin.at \beta=0} = \frac{2\tau_y}{c+e} \quad \text{and} \quad g_{Pmin.at \beta=\pi} = \frac{2\tau_y}{c-e} \dots\dots\dots (16)$$

Equation similar to equation (16) were derived in 1990 by Luo and Peden [5] in which $g_{Pmin.at \beta=0}$, and $g_{Pmin.at \beta=\pi}$ are minimum pressure gradient required to initiate the flow at the maximum annular clearance and over the entire eccentric annulus respectively. It is clear from the above equations that there will be three flow conditions occur depending on the value of frictional pressure gradient as follows;

- 1- No flow condition in which $0 \leq g_{Pe} \leq g_{Pmin.at \beta=0}$, provided that $y_o \geq h_{max.}/2$.
- 2- Flow will occur in the wider gap ($h_{min.}/2 < y_o \leq h_{max.}/2$) of the annulus only when $g_{Pmin.at \beta=0} < g_{Pe} \leq g_{Pmin.at \beta=\pi}$.
- 3- Flow will occur over the entire cross section of eccentric annulus i.e. $y_o < h_{min.}/2$ if

$$g_{Pe} > g_{Pmin.at \beta=\pi}$$

I will consider one half of the annulus, because the velocity profiles are same in both halves, so for; $0 \leq \beta \leq \pi$, referring to Figure (2), for the triangle (a o b), applying cosine rule to obtain; $r_o^2 = (h + r_i)^2 + e^2 - 2e(h + r_i)\cos\beta$ then:

$$\beta = \cos^{-1} \left[\frac{(h+r_i)^2 + e^2 - r_o^2}{2e(h+r_i)} \right] \dots\dots\dots (17)$$

Referring to Figure (4) at the interface between the part of an eccentric annulus that open to flow and another part which contained stagnant fluid,

$$\beta = \beta_o \text{ at } h = 2y_o \text{ and equation 17 becomes;}$$

$$\beta_o = \cos^{-1} \left[\frac{(2y_o + r_i)^2 + e^2 - r_o^2}{2e(2y_o + r_i)} \right] \dots\dots\dots (18)$$

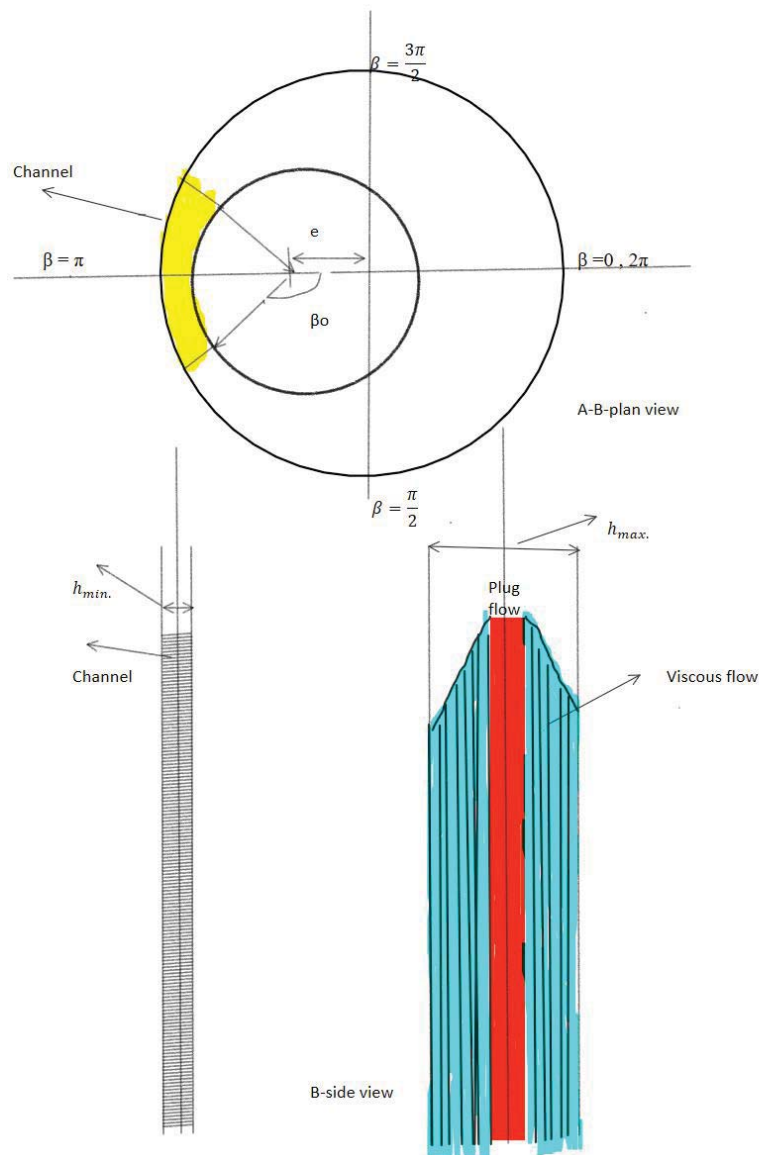

Fig. (4) Illustration of the channel through the flow geometry of an eccentric annulus [9].

The fluid in the area enclosed by $0 \leq \beta < \beta_0$ represent the flowing fluid ,while the fluid in the area enclosed by $\beta_0 \leq \beta \leq \pi$ represent the stagnant fluid or channel, if $\beta_0 = \pi$ the flow becomes over the entire cross–section of eccentric annulus, and channel will not exist in the annulus.

Due to the limitation of the space in this paper, , the flow equation using Bingham model was derived by Uner et.al. [15] Using incorrect integration limits this equation re derived by Riayde [9] after correcting integration limits which take the following form in field units;

$$g_{Pe} = 4.1772 \times 10^{-6} \frac{\mu_P V_m (2 E_2 - \pi r^*)}{r_o^2 [I_2 + 4\beta_o T_o^3 - 3I_1 T_o]} \dots\dots\dots (19)$$

The method of calculating integrals I_1, I_2 & T_o is presented in the next section.

B- Using Casson Model;

Casson model has the following form;

$$\tau^{1/2} = \tau_y^{1/2} + \mu_\alpha^{1/2} \gamma^{1/2} \quad \text{for} \quad y_o < y \leq \frac{h}{2} \dots\dots\dots (20)$$

$$\gamma = \frac{dv}{dy} = 0 \quad \text{for} \quad 0 < y \leq y_o \dots\dots\dots (21)$$

The details for derivation haven't been presented here, only the final form of the flow equation will be presented here, the final form in the field units is;

$$g_{Pe} = \frac{3.481 \times 10^{-7} \mu_\infty V_m (2 E_2 - \pi r^*)}{r_o^2 \left[\frac{1}{12} I_2 - \frac{\sqrt{2}}{5} I_3 \sqrt{T_o} + \frac{1}{4} I_1 T_o - \frac{1}{15} \beta_o T_o^3 \right]} \dots\dots\dots (22)$$

Where;

$$I_3 = \frac{1}{r_o^{2.5}} \int_0^{\beta_o} h^{2.5} d\beta$$

The method of calculating integrals I_3 can be shown in section (C).

C-Using Modified Power-Law Model;

This model has the following form;

$$\tau = \tau_y + K_1 \left(-\frac{dv}{dy} \right)^{n_1} \quad \text{for} \quad y_o < y \leq \frac{h}{2} \dots\dots\dots (23)$$

$$\gamma = \frac{dv}{dy} = 0 \quad \text{for} \quad 0 < y \leq y_o \dots\dots\dots (24)$$

The details for derivation haven't been presented here, only the final form of the flow equation will be presented here, the final form in the field units is;

$$g_{Pe} = \frac{K_1}{600 r_o} \left[\frac{0.4 V_m n_2 (2 E_2 - \pi r^*)}{r_o [(1+n_1)Z_2 + 2T_o(1+2n_1)Z_1]} \right]^{n_1} \dots\dots\dots (25)$$

Where;

$$n_2 = \frac{(1+2n_1)(1+n_1)}{n_1}, \quad h_1 = h/r_o, \quad S_1 = 1/n_1$$

$$Z_1 = \int_0^{\beta_o} (h_1 - 4T_o)^{(S_1+1)} d\beta \quad \text{and,}$$

$$Z_2 = \int_0^{\beta_o} (h_1 - 4T_o)^{(S_1+2)} d\beta \dots\dots\dots(26)$$

D-Using Modified Robertson-Stiff Model;

In 1989 Saleh [13] proposed the following formula;

$$\tau = \tau_y + A_1 \left(-\frac{dv}{dy} + C \right)^{B_1} \quad \text{for} \quad y_o < y \leq \frac{h}{2} \dots\dots\dots (27)$$

$$\gamma = -\frac{dv}{dy} + C_1 = 0 \quad \text{for} \quad 0 < y \leq y_o \dots\dots\dots (28)$$

The details for derivation haven't been presented here, only the final form of the flow equation will be presented here, the final form in the field units are;

$$g_{Pe} = \frac{A_1}{600 r_o} \left[\frac{B_2 [(0.4 V_m (2 E_2 - \pi r^*) / r_o) + 0.5 C_1 I_1]}{(1+B_1) Z_4 + 2 T_o Z_3 (1+2B_1)} \right]^{B_1} \dots\dots\dots (29)$$

In which;

$$B_2 = \frac{(1+2B_1)(1+B_1)}{B_1}, \quad Z_3 = \int_0^{\beta_o} (h_1 - 4T_o)^{\left(\frac{1+B_1}{B_1}\right)} d\beta,$$

$$Z_4 = \int_0^{\beta_o} (h_1 - 4T_o)^{\left(\frac{1+2B_1}{B_1}\right)} d\beta \dots\dots\dots (30)$$

The procedure used for calculating some functions presented in the above equations are outlined now:

a-The functions E_1 and E_2 are complete elliptic integrals for the first and second kinds, respectively. They are calculated by using the following series [13].

$$E_1 = \frac{\pi}{2} (1 + m_2) \left[1 + \frac{1^2}{2^2} m_2^2 + \frac{1^2 x^3^2}{2^2 x^4^2} m_2^4 + \frac{1^2 x^3^2 x^5^2}{2^2 x^4^2 x^6^2} m_2^6 + \dots \right] \dots\dots\dots(31)$$

$$E_2 = \frac{\pi}{2(1+m_2)} \left[1 + \frac{1^2}{2^2} m_2^2 + \frac{1^2}{2^2 x^4^2} m_2^4 + \frac{1^2 x^3^2}{2^2 x^4^2 x^6^2} m_2^6 + \dots \right] \dots\dots\dots (32)$$

Where: $m_2 = \frac{1-m_1}{1+m_1}, \quad m_1 = \sqrt{1-M^2}$

b- The integrals $J, J1, J2, I1, I2, I3, Z1, Z2, Z3,$ and Z_4 are evaluated numerically using the 15 points Gauss-Legendre quadrature method [9].

Model Description:

The minimum flow rate $Q_{min.}$ is the minimum rate required to start flow through the smallest gap in the eccentric annulus, in order to prevent channel formation as illustrated in Figure (4) . $Q_{min.}$ is the flow rate that corresponds to minimum frictional pressure gradient required to exceed the yield stress in the smallest part of eccentric annulus $g_{Pmin.at \beta=\pi}$ as defined in Eq.(16) and in field units it becomes;

$$g_{Pmin.at \beta=\pi} = \frac{\tau_y}{600 (c-e)} \dots \dots \dots (33)$$

To calculate the value of $Q_{min.}$, the value of pressure gradient $g_{Pmin.at \beta=\pi}$ is now substituted into one of the equations that derived to relate the frictional pressure gradient with the flow rate depending on the rheology of cement slurry.

Hydraulic Design for cement job:

Using the equations that have been derived and presented in this paper to design step by step procedure to determine the minimum rate required to start flow through the smallest gap in the eccentric annulus to avoid bad cement job.

Required data:

- 1- Fann-V-G meter reading at 3, 6, 100, 200, 300, 600 rpm ($\theta_3, \theta_6, \theta_{100}, \theta_{200}, \theta_{300},$ and θ_{600})
- 2- Density of the cement slurry.
- 3- Casing outside diameter and hole size.
- 4- Real hole path (inclination angle as a function of depth).
- 5- Casing centralizers program.

Application procedure;

- 1- Calculate rheological parameters for all adopted models, the equations presented in Reference (13), then calculate shear stress values for the following shear rate values (3, 6, 100, 200, 300, 600 rpm) for each rheological model.

- 2- Select the best model that fit the actual rheogram of cement slurry, actual (measured) values can be calculated from:

$$\tau = 1.067 \times \theta \dots\dots\dots (34)$$

$$\gamma = 1.703 \times rpm \dots\dots\dots (35)$$

Then compare the measured values with that calculated in step one to choose the best rheological models that gives lowest AAPE.

- 3- Dividing the well into a number of sections, depending on the annulus dimensions and the hole inclination angle.
- 4- Assume a value for the eccentricity for each section of the well depending on hole inclination angle and centralizers program.
- 5- Calculate the required integrals, the geometric parameters, and the turbulent hydraulic diameter for each section using equations presented in [11].
- 6- Calculate the minimum flow rate in the worst section, (section with high value of eccentricity). If the value of Q_{min} is too high and cannot obtained practically due to pump limitations, change centralizer program to reduce the value of eccentricity which in turn reduce the value of Q_{min} .
- 7- Calculate the value of the average fluid velocity, and Kozicki Reynold number, in order to estimate the flow regime using equations presented in [11].
- 8- Calculate total pressure drop in the system.
- 9- Calculate the pump capacity required to perform the job.

Conclusions:

1-Using Bingham, Robertson-Stiff, Casson, Modified Power-law, and Modified Robertson-Stiff models to derive laminar flow equations by assuming that an eccentric annulus can be simulated as slit of variable height for high values of radius ratio.

2-The pressure drop due to friction decrease as the eccentricity increase for a given annulus dimensions, while the frictional pressure drop increase as radius ratio increase for a fixed value of eccentricity.

3- The velocity profile for laminar flow for all adopted rheological models has been determined. This profile indicates that the velocity values in the wide portions of the annulus are greater than those in the narrow portions and it approach zero value throughout the channel.

4-Based on the derived equations in this study for fluid flow of Non-Newtonian fluids with a yield stress through an eccentric annulus, the flow may not occur over the entire cross section of the eccentric annulus as well as the flow regime may change between the wide and narrow portions of the same cross sectional area.

5-A step by step procedure has been presented to determine the minimum flow rate that we need to use during cementing operation to avoid bad cement behind the casing as well as, the determination of minimum pump capacity during cementing operation.

Nomenclature:

A, A_1 = Robertson-Stiff and Modified Robertson-Stiff Parameters, respectively, lb.sec.^B/100 ft²

$AAPE$ = Average absolute percentage error, Percent.

B, B_1 = Robertson-Stiff and Modified Robertson-Stiff Parameters, respectively, dimensionless.

c = concentric annulus clearance, in.

C, C_1 = Robertson-Stiff and Modified Robertson-Stiff Parameters, respectively, sec⁻¹.

e = inner pipe offset relative to outer pipe center, in.

E_1, E_2 = complete elliptic integrals of first and second kind, respectively.

g_{Pe} = frictional pressure gradient for eccentric annulus, psi/ft.

$g_{Pmin.@\beta=0}$ = minimum frictional pressure gradient required to initiate the flow in the wider gap portion of eccentric annulus, psi/ft.

$g_{Pmin.@\beta=\pi}$ = minimum frictional pressure gradient required to initiate the flow in the entire cross-sectional area of eccentric annulus, psi/ft.

h = local annular clearance or slit height, in.

$h_{max.}$ = maximum annular clearance, in.

$h_{min.}$ = minimum annular clearance, in.

H_1 = integral defined by equation 12.

K, K_1 = power-law and modified power-law parameters, respectively, lb.sec.ⁿ/100 ft²

n, n_1 = power-law and modified power-law exponents, respectively, dimensionless.

$Q_{min.}$ = minimum flow rate to initiate the flow over the entire eccentric annulus, gpm.

r^* = radius ratio, dimensionless.

r_i, r_o = inner, and outer pipe radius , respectively , in.

rpm = shear rate, rpm.

S, S_l = reciprocal of power-law , and modified power-law exponents, respectively.

β = eccentric angle defined in Fig(4),radian

β_o = eccentric angle at $y_o=h/2$, radian

γ = shear rate, sec.⁻¹

ϵ =casing hole eccentricity, fraction

$\theta_3, \theta_6, \theta_{100}, \theta_{200}, \theta_{300}$, and θ_{600} =Fann-V-G meter reading at 3,6,100,200,300,600 rpm respectively, dial reading.

μ_p = plastic viscosity, c.P.

μ_∞ = viscosity at infinite shear rate, c.P

τ = shear stress, lb/100 ft².

τ_y = yield stress, lb/100 ft².

References:

1. Alexandre Lavrov (2016), " Effect of eccentric annulus, washouts and breakouts on well cementing quality: Laminar regime" Energy Procedia 86, 391 – 400
2. Guckes,T.L. (1975), "Laminar flow of non-Newtonian fluid in an eccentric annulus" Trans. ASME.(498-506)
3. Isgenderov I, et al. (2014), " ECD management solves lost circulation issues in cementing narrow pressure window: a case study". IADC/SPE paper 170491 presented at the IADC/SPE Asia Pacific Drilling Technology Conference held in Bangkok, Thailand, 25-27.
4. Iyoho, A.W. (1980), "Drill cutting transport by non-Newtonian drilling fluids through eccentric annuli." PhD dissertation, U. of Tulsa (OK).
5. Luo, Y. and Peden, J.M. (1990), "Flow of non-Newtonian fluid through an eccentric annuli" SPEPE (91-96).
6. Mitsuishi,N. and Aoyagi,Y. (1973)." Non-Newtonian fluid flow in an eccentric annulus" J. Chem. ENG. Japan,6 (402-408)
7. M. Zulqarnain (2012), "Simulations of the primary cement placement in annular geometries during well completion using computational fluid dynamics (CFD)", Msc Thesis, The Craft and Hawkins Department of Petroleum Engineering, Louisiana State Univ, USA.
8. Polina R. Khalilova et.al. (2013), "Newtonian Fluid in Cementing Operations in Deepwater Wells: Friend or Foe?" SPE Annual Technical Conference and Exhibition, New Orleans, Louisiana, USA
9. Riayde H. Jawad (1992), "Flow of Non-Newtonian Fluid Through Eccentric Annuli with Carrying Capacity Design for Directional Wells ". M. Sc. Thesis, Baghdad University, Baghdad, Iraq.
10. Riayde H. Jawad & Ziad Aswad (1993), "A new approach for cutting transport by non-Newtonian fluids through eccentric annuli" 12th Int. Conference of slurry transport, Brogue, Belgium.
11. Riayde H. Jawad & Ziad Aswad (1993), "Turbulent flow of Non-Newtonian fluid through an eccentric annulus" Al-Muhandis journal, Vol.116, No.4, pp 58-70, Baghdad-Iraq.

12. Sairam PKS and Krishna Babu Yerubandi (2010), "Slim Well Completions: A 3D Numerical Approach for Displacement to Design Effective Cementing Fluids " Trinidad and Tobago Energy Resources Conference, Port of Spain, Trinidad.
13. Saleh, M. M. (1989), "Carring capacity design for rotary drilling operation" Msc. Thesis, university of Baghdad, Baghdad.
14. Sviatoslav Pelipenko (2000), " Displacement flow of Non-Newtonian fluid in an eccentric annulus" Ms.c thesis ,Oxford university.
15. Uner(1988) "Solution for Non-Newtonian flow in eccentric Annulus"Ind.Eng.Chem.Res.27 (698-701)
16. Vaughn (1965), "Axial laminar flow of non-Newtonian fluid in narrow eccentric annuli" SPE J. (277-280).