

## **Hydrodynamic Characteristics Effect of Foam Control in a Three-Phase Fluidized Bed Column**

Mohammad Fadhil \* , Ahmed Ali Hadiand\*\* , Shakir Mahmood Ahmed\*\*\*

\*Department of Chemical Engineering, University of Technology Baghdad, Iraq,

\*\*Ministry of Oil, Pipelines Company, Baghdad, Iraq,

\*\*\*Ministry of Oil, SCOP, Baghdad, Iraq.

### **Abstract**

The present work was devoted to study the effect of operating parameters (e.g., superficial gas and liquid velocities, size of solid particles, volume percentage of particles loaded in column and type of particles) on foams, and to investigate the process of foam suppression.

The experimental apparatus was operated in continuous mode for the two phases (i.e. air and a solution of aqueous anionic surfactant). Sands which were considered as hydrophilic behavior particles were used as solid phase. A specific surface treatment was performed on hydrophilic sands particles to transfer it into hydrophobic one. These two versions of sands were used in the experimental setup respectively to study their effect on suppression of foams. The average gas holdup for the entire column was measured by means of the local gas holdup which was computed from the pressure difference in each segment of the column. Local solid concentration along the column was measured experimentally by analyzing the samples of mixture drawn from the sampling ports. From the present

work it was found that: Flow regimes of multiphase system could be easily determined by utilizing local gas holdup profile measured by pressure drop transducer method. The transition from the homogenous to heterogeneous regime was advanced, from  $u_g=4$  to  $2\text{cm/s}$  with increasing solid concentration from 10 to 20%v and decreasing average particle diameter from  $d_p=(0.8)$  to  $(0.25)$  mm.

When a mixture of water/surfactant was employed in the bubble column, foam could be present depending on the input operating parameters. The fluid mechanism of foam suppression with hydrophilic particles was enhanced by a direct attack on the foam by hydrophobic particles (i.e. hydrophobic particles were more effective in retaining liquid–destroying foam than the hydrophilic particles). It was found that hydrophobic particles of 0.25 mm average diameter and 10%v loading in the reactor could reduce foaming fraction from 0.85 to 0.15 if the liquid velocity was 0.3 cm/s. The foaming fraction could be reduced to 0.0 if the liquid velocity increased to 0.4 cm/s. The results of this study may have abroad applications in petroleum and petrochemical industries where liquid hydrocarbons are processed.

### الخلاصة

البحث الحالي يتضمن دراسة تأثير الظروف التشغيلية ( السرعة السطحية للغاز والسائل, حجم الدقائق الصلبة, النسبة الحجمية للدقائق المحملة في العمود ونوع تلك الدقائق) على معدل تكون الرغوة في عمود يعمل بسائل هيدروكربوني وبنظام التشغيل المستمر وكذلك دراسة ايجاد طريقة بسيطة وغير مكلفة للسيطره على الرغوه. من خلال البحث الحالي تم

استنتاج الاتي : عند اضافة المواد الهيدروكربونية السائلة داخل المفاعل يمكن للرغوة ان تظهر اعتمادا على الظروف التشغيلية. يمكن بدقه تحديد نقطة التحول من النظام المتجانس الى الاضطرابي بقياس القيم الموقعية للغاز المحتجز على امتداد العمود. استقرارية نظام التدفق المتجانس تزداد بزيادة قطر الجزيئه وقله النسبه الحجميه للماده الصلبه في العمود, حيث ان نقطة التحول تقل من 4 سم<sup>3</sup> الى 2 سم<sup>3</sup> عند زيادة النسبه الحجميه للماده الصلبه من 10 % الى 20 % و تقليل قطر الجزيئه من 0.8 ملم الى 0.25 ملم . كما وجد ان ميكانيكية المائع لتقليل الرغوة باستخدام الدقائق الصلبة ( Solid particles ) المحبة للماء ( Hydrophilic ) يمكن تسريعها لمهاجمه فقاعات الرغوة بتحويل الدقائق الـ (Hydrophilic) الى دقائق كارهه للماء (Hydrophobic) وقد استخدمت طريقة عمليه- يمكن استخدامها صناعيا- لتحويل الدقائق الصلبة الى (Hydrophobic) حيث تم تقليل الحجم اللابيدي للرغوة من 0.85 الى 0.15 عند استخدام دقائق كارهه للماء (Hydrophobic) ذات القطر 0.25 ملم وسرعة سائل 3 و0 سم<sup>3</sup>, كما ان بزيادة سرعة السائل الى 4 و0 سم<sup>3</sup> يتم التخلص من الرغوة تماما. يعتقد بان نتائج هذه الدراسة لها تطبيقات واسعة في مجال الصناعات النفطية والبتروكيمياوية.

**Keywords:** Three-phase fluidized-bed column, local gas holdup, foam suppression, hydrophobicity.

### **Introduction**

Foams and foaming pose important questions and problems for the chemical industry in general. Foam can be desirable such as in bioreactors where it acts as a cushion preventing bursting bubbles from damaging the cells at the liquid surface [24]. In the oil industry, foams are used in under-balanced drilling, for reservoir clean-up and for enhanced oil recovery in porous sand [3].

On the other hand, excessive foaming might create serious problems in many industrial processes. Foam can reduce throughput and separation performance or can even cause contamination of products due to takeover of foam from other vessels [15] [28]. In hydrocracking and other foaming reactors, the foam rises to the top because it has a higher gas fraction than the bubbly mixture from which it comes. The high gas hold-up in foams is undesirable in chemical reactors because it strongly decreases the liquid residence time and in hydrocracking reactors also promotes the formation of coke [10]. The hydrodynamics in a gas-liquid or gas-liquid-solid reactor are characterized by different flow regimes, namely, the homogeneous, transition, and heterogeneous regimes, mainly depending on the superficial gas velocity. The homogeneous regime exists at low superficial gas velocities and changes to the heterogeneous regime with an increase in the superficial gas velocity.

Industrial interest for gas-liquid-solid processes is in the heterogeneous flow regime [21][17]. The hydrodynamics, heat and mass transfer, and mixing behavior are quite different in different regimes [12].

It is reported that the basic factors affecting gas holdup are: superficial gas velocity, liquid properties, column dimensions, operating temperature and pressure, gas distributor design, and solid phase properties [25]. They found that the spatial variation of gas holdup is another important factor which gives rise to pressure

variation and thus liquid recirculation. Since liquid recirculation plays an important role in mixing and heat and mass transfer. The superficial gas velocity is the dominant factor that influences gas holdup. With increasing superficial gas velocity, gas holdup increases, less pronounced in the heterogeneous regime than in the homogeneous regime, and numerous experimental studies reported these findings, it was found that increasing the liquid velocity significantly increased volumetric mass transfer coefficient but only slightly increased the gas holdup [10-17]. A slight increase in gas holdup with increasing superficial liquid velocity was reported by [18, 15]. It was found that the influence of the liquid velocity on gas holdup became more pronounced at high pressures [14].

The effect of solid concentration on gas holdup has been investigated by a number of researchers [19- 23] who concluded that an increase in solids concentration generally reduced the gas holdup. Also It was reported that for low solids loading (<5 vol. %), the behavior of the slurry bubble column is close to that of a solid free bubble column [21].

The effect of surface-active agents on the phase holdups of a gas-liquid bubble column and three-phase fluidized bed (with glass beads of 1.2 and 5.0 mm) was studied by [24]. The results showed that the presence of surface-active agents increased the gas holdup in a bubble column by an average of 41% and increased the gas holdup in

a three-phase fluidized bed by an average of 37%. The presence of electrolyt or impurities was also found to increase the gas holdup [25].

Foam control agents are usually cracked under the severe condition present in the reactors. For example, in hydrocracking reactor, anti-foam agents are exposed to hydrogen pressures over (100 bar) and temperature of ( $140C^{\circ}$ ) or higher. Anti-foaming agents tend to crack into different chemical products which contaminate the liquid and gas in the reactor, such cracking of anti-foaming agents also tends to increase the operating costs of the overall process [24]. Prior literature [2, 26] on the use of particles to destroy foam described effects of hydrophobic particles which attack the foam. Adhesion of air bubbles to Teflon-coated glass beads were observed to be fluidized in water [1]. The phenomenon of bubble adhesion to the non-wettable particle leads to a decrease in the apparent density of the particle, which in turn is responsible for a larger bed expansion and smaller gas holdup compared with wettable particle systems. Non-wettable particles can be used to thin or reduce foam layers, and consequently reduce foam formation [7]. The characteristics of water-air-solid fluidization with non-wettable (hydrophobic) particles and were studied and classified of the flow pattern according to the motion of the particle-bubble aggregates [29].

The aim of the present work is to study the role of fluidized particulates in a hydrocarbon stream flowing in a three phase contactor, and to develop a simple and inexpensive process for foam

suppression which can be employed in the petroleum industries especially in the hydroconversion reactor without requiring excessive additional materials.

**Material and methods:**

Experiments were carried out at the department of chemical engineering laboratory at the University of Technology in Baghdad-Iraq. The schematic layout of the process used in this work is shown in fig. (1). The operating column is a cylindrical Plexiglas column with dimensions of (12.5 cm I.D. and 125 cm high), the cylindrical column was placed in a Plexiglas column of a square section with dimensions of (18cm\*18cm\*90cm), the annular space was filled with water. The slit geometry allows us to observe the flow pattern and to determine the presence of foam. The inner column had (5) sample ports and also (5) pressure tapes located along the column all arranged axially. All pressure taps were connected to a pressure difference transmitter (Rosemont<sup>®</sup> 4-20mA, 0-2500 mmH<sub>2</sub>O) which converted the pressure signal to a mV, and via an interface to digital signal which converted by a PC computer to pressure time average signal. At the bottom of column a gas distributor was designed to secure flow stability (i.e.,  $We \geq 2$  and  $Fr \geq 0.37$ ) and optimum free area for gas flow with (88) holes each hole is (2 mm) in diameter. Air was utilized as the gases phase which supplying to the bottom of the column by means of compressor (Assmol<sup>®</sup>, Italy). The gas flow rate was adjusted with a needle valve and a calibrated rotameter. The liquid was pumped

at the bottom of the column through a (25 m) head centrifugal pump (stream<sup>®</sup>) and adjusted by a needle valve and calibrated flow meter. The foaming system is selected to give a maximum foaminess in the operating column. To specify desired foaming system; different types of alcoholic aqueous solution were tested using the shaking test bottle [2]. Light gas oil, heavy gas oil (VGO), tetra butanol, propanol, and glycerin were prepared in different concentrations with water., Although the foaming system which gave maximum foaming (i.e., 80%) was light gasoil, a 1wt. % glycerin in water was used in the present work, because the former generated oily spots on the inside walls of the column resulting of bad visual observation. Results of the shaking test are shown graphically in fig. (2). Table (1) represents the specification of the surfactants used in this work.

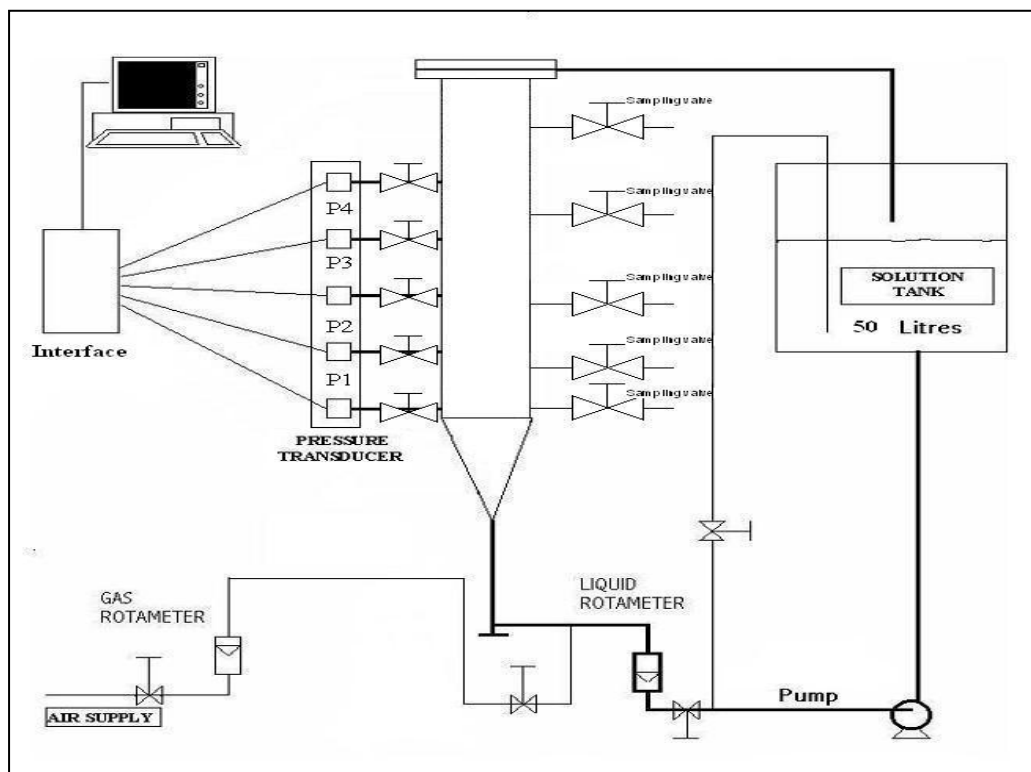

Fig. (1) Schematic of the bubble column apparatus used in the experiments



Table (1) Properties of surface active agents used in experiments [30].

Surfactant name	Purity%	M.wt.	Density [gm/cc] At 20 (°C)	Boiling point (°C)	Supplier
Tetra. Butanol	99	74.12	0.77	83	Riedel-DeHAën AG Sneeze Hannover
Propanol	99	60.1	0.80	97.1	Riedel-DeHAën AG Sneeze Hannover
Glycerin	99	92.092	1.26	290	Riedel-DeHAën AG Sneeze Hannover
Light gas oil	(-)	(-)	0.83 At 15.4 (°C)	230	Al-Doura refinery
Heavy gas oil (VGO)	(-)	(-)	0.85 At 15.4 (°C)	390	Al-Doura refinery

According to [5], the particle size and density of the particles to be added are preferably selected so as to provide a minimum fluidization velocity ( $U_{mf}$ ) which is less than the desired superficial velocity ( $v_l$ ), and to provide particle settling velocity in the liquid phase ( $U_t$ ) which is greater than the superficial liquid velocity [10]. Thus, the particle size and density are preferably selected so as to provide ( $U_{mf} < v_l$ ) and ( $U_t > v_l$ ).

This advantageously serves to cause the particles to expand the fluidized bed in bubbly liquid mixture below the foam. In the present work, sands which happen to be hydrophilic were used as solid phase. The properties of sand particles are shown in Table (2).

Table (2) the properties of sand particles

$d_b$ (mm)	$\rho_p$ [gm/cm <sup>3</sup> ]	$U_t$ (cm/s)	$U_{mf}$ (cm/s)
0.2-0.3	2.50	8.2-10.3	0.114-0.192
0.4-0.6	2.50	12.2-14.5	0.277-0.464
0.7-0.9	2.50	15.6-18.9	0.565-0.778
<b>1.0-1.5</b>	<b>2.50</b>	<b>20.6-26.4</b>	<b>0.89-1.49</b>

In the present work gas and liquid superficial velocities were specified according to Table (2).

Hydrophilic sands were converted into hydrophobic using the method of [31]. It was reported that hydrogen bonds formed from reactions of hydrophobic alcohols with surface silanol content appear to be more stable at high operating temperature that is equivalent to the operating temperature of the hydroconversion reactor.

In the present work, octanol was used as the liquid carrier of the solid particles. The resulting mixture was heated below the boiling point of octanol (i.e. 178 °C) for a time period of (4 hrs) which was sufficient to cause the silica to chemically react with the substantially hydrophobic alcohol.

To examine the degree of hydrophobicity of surface treated particles, a method suggested by [32] was utilized to verify the particles affinity to the 1wt% glycerin in water solution, they characterized of the used particles by simple visual observation. If one pours ordinary sands in a container with water, it will smoothly, and grain by grain, fall to the bottom. If one does the same thing with

hydrophobic sand, a different behavior follows: some of the grains stay at the surface; most of them fall to the bottom in large aggregates covered with a thin layer of air. In the present work, factorial design method was used for planning the experiments because of its reliability in finding out the effects and interaction between the controlled variables of the operating system. The real values of controlled variables (F) and their corresponding levels (L) are shown in Table (3).

**Table (3) Selected levels and factors**

F	Real variables			
	Average particle diameter (mm)	Liquid flow rate $L \text{ min}^{-1}$	Gas flow rate $L \text{ min}^{-1}$	Solid concentration vol. %
1	0.25	0.75	22	0
2	0.55	1.50	44	10
3	0.75	2.95	73.5	
4	1.0	4.42	117.5	20

**Theoretical Aspect**

Axial local gas holdup along the operating column was measured using the pressure drop between two adjacent points separated by a distance ( $h_{i-j}$ ) which is measured directly by the ( $\Delta P$ ) transmitter:

$$\varepsilon_{g_{i-j}} = 1 - \frac{\Delta P_{i-j}}{g\rho_l h_{i-j}} \dots\dots\dots (1)$$

Equation (1) can be used to predict the gas holdup profile along the column.

When  $\Delta P = \Delta P_t$  and  $h_{i-j} = L$  equation (2) can be used to evaluate the total average gas holdup:

$$\varepsilon_{g_{av.}} = 1 - \frac{\Delta P_t}{g\rho_l L} \dots\dots\dots (2)$$

The foaminess is calculated as follows [2]:

$$\varepsilon_f = \frac{X_f}{H} \dots\dots\dots (3)$$

**Results and discussion**

Figs. (3-7) describe the local gas holdup along the column height as a function of gas superficial velocity and at fixed liquid superficial velocity of 0.152 (cm/s) and for 10% volume fraction of two different version of sands. These figures show that an increase in gas superficial velocity results an increase in local gas holdup and a slight deviation from the linear trend. Location of transition point from bubbly flow to churn one is clearly observed from the local gas holdup profile at each tested section of the column. The figures show also the effect of different column heights on local gas holdup. In the bubbly flow regime, a proportional effect between column height and local gas holdup is established, this may be explained according to the kinetic energy of bubbles, which has maximum value near the gas sparger and consequently higher bubble velocity which means lower residence time through the first section of the column and a lower local gas holdup. In the turbulent region and due to the increasing rate of bubble

production from sparger, a higher number of small bubbles per unit volume is existed in the lower section of the column which means higher gas holdup.

The effect of solid particles on stability of the bubbly flow regime is shown in fig. (3-7), the inception of the transition region in fig. (4-7) start at lower gas velocity compared to the system shown in fig. (3). This early inception is attributed to bubble coalescence enhanced by the presence of smaller solid particles. Bubble coalescence resulting in lower local gas holdup. Analysis of Figs. (4-7) shows that the particle diameter has an adverse effect on the stability of the bubbly flow regime. Also Figure 4 to Figure 7 show that hydrophobic particles slightly decrease local gas holdup more than hydrophilic ones. This can be attributed to the phenomenon of gas bubble sticking to the hydrophobic particles results an increase in bubbly mixture density and consequently a decrease in gas holdup according to equation (2).

Fig. (8) and (9) show gas holdup as a function of the gas velocity at liquid velocities of 0.152 cm/s and 0.30 cm/s, respectively. As shown the liquid flow rate has an adverse effect on the average gas holdup. This was verified by equation ( $\varepsilon_s + \varepsilon_l + \varepsilon_g = 1$ ), which stated that for a three-phase dispersion mixture the sum of the phases fraction is equal to one, and increasing of a specified phase is on the account of other phases.

Fig. (10) shows the effect of particle diameter on average gas holdup while fig. (11) shows the effect of solid concentration on average gas holdup. These Figures show that the smaller the particle diameter the smaller the gas holdup. This may be due to accumulation of smaller particles at gas-liquid interface of bubbles increasing the drainage rate of liquid between adjacent bubbles and consequently to enhance the rate of bubble coalescence. As can be seen increasing the solid loading results in decreasing the gas holdup. This can be attributed to increase the "pseudo-viscosity" of the suspension which promotes the coalescence of bubbles resulting in an increase in bubble size and bubble rise velocity, consequently a decrease in a gas holdup.

Fig. (12-13) plot the foam fraction as a function of the gas velocity at liquid velocities of 0.152 cm/s and 0.30 cm/s, respectively. We observe that the hydrophobic particles suppressed the foam substantially better than their hydrophilic counterparts. Evidently the fluid mechanics of foam suppression with hydrophilic particles are enhanced by a direct attack on the foam by hydrophobic particles.

This enhancement is attributed to decreasing of the apparent density of the hydrophobic particles comparing with that of the hydrophilics resulting in easily attack to the foamed region which appeared at the top of the reactor.

The experimental results are presented in fig. (14), show this time for 10% volume fraction of the hydrophilic and hydrophobic sands with a mean size of (700-900)  $\mu\text{m}$ . Again, we observe a better

foam suppression by the hydrophobic particles at liquid velocity 0.152 (cm/s). Figs. (15-16) show the foam fraction as a function of the gas velocity at liquid velocities of 0.0764 cm/s and 0.152 cm/s respectively, for the surfactant solution without particles and with 10% volume fraction of hydrophilic and hydrophobic sand, with a mean size of  $(400-600)\mu m$ . As expected, the hydrophobic particles suppress foam fraction better than their hydrophilic counterparts. And as can be seen, increasing particles diameter has a proportional effect on the foam formation, while increasing liquid superficial velocity has an adverse effect on the foam formation.

In fig. (17), the foam fraction as a function of the gas velocity at a liquid velocity of 0.152 cm/s are compared for three mean size ranges;  $(200-300)\mu m$ ,  $(400-600)\mu m$  and  $(700-900)\mu m$ , for hydrophobic sand. As expected the smaller particles suppressed better the foam formation. Foam fraction seems to reach a plateau and even a change of slope in the foam curve at a gas velocity of approximately 8 cm/s. They expanded so well and penetrated the foam so easily, that a large accumulation of particles was observed at the top of the column.

In fig. (18), the foam fraction as a function of the gas velocity at a liquid velocity of 0.152 cm/s are compared for two different volume fractions (10% and 20%) of the hydrophobic sand with a mean size of  $(700-900)\mu m$ . As expected, the foam suppression was favored by the presence of the highest solid fraction, because rate of foam destruction

is proportional to the density of hydrophobic particles/ liquid suspension. Fig. (19-a, b, c) and (20-a, b, c) show , the concentration profile of (200-300)  $\mu\text{m}$  for 10% solid loading hydrophilic and hydrophobic particles respectively. These smaller particles of fig. (19) are not present at the bottom of the bed and their concentration profiles reach a maximum value at a height that depends on fluidization conditions. The concentration profiles for these particles shift to a higher axial dispersion gradient as the velocity of the liquid increases. Fig. (20) which represent the axial concentration profile of the hydrophobic particles show that the bulk density of solid bed at each point along the column is shifting to higher levels compared with that of hydrophilic counterparts. This is due to the reduction in apparent density of hydrophobic particles which enhances the capability to move upwards more easily and attack the foams which exist at the upper parts of the reactor. A qualitative description of the differences in the bed expansion of the hydrophobic and hydrophilic particles is of interest. Hydrophobic particles expand more readily than the corresponding hydrophilic particles. More of the hydrophobic particles penetrate the foam and rise to the screen at the top of the reactor. When the flow is stopped, hydrophobic particles accumulate at the foam interface, because of trapped air as in flotation. These are marked on Fig. (19-20) at  $h=80$  cm (i.e., at the top of dispersion). As can be seen the concentrations of the hydrophobic particles are more than that of the hydrophilics.



### **Conclusions**

1. Flow regimes of multiphase system can be easily determined by utilizing local gas holdup profile measured by pressure drop transducer method.
2. The transition from the homogenous to heterogeneous regime is advanced with increasing solid concentration and decreasing particle diameter.
3. Foam appears above a bubble mixture when the superficial gas velocity is greater than a critical value. At any fixed gas velocity  $U_g$ , foam may be eliminated with increasing of  $U_l$ .
4. The fluid mechanism of foam suppression with hydrophilic particles are enhanced by a direct attack on the foam by hydrophobic particles (i.e. hydrophobic particle are more effective in retaining liquid – destroying foam than the hydrophilic particles) and they may have abroad applications in petroleum and petrochemical industries where liquid hydrocarbons are processed.
5. The fluidization of particles always increases the hold-up of solids plus liquid; if the particle size is not too large the liquid hold-up itself is increased by fluidizing particles. For a fixed solids volume fraction (i.e., 10 vol. %), the (200-300)  $\mu\text{m}$  hydrophobic particles are more effective in retraining liquid (destroying foam) than the other hydrophilic particles which have higher particle diameter. The smaller particles expand so well and penetrate the foam so easily, that the accumulation of particles at the top of the reactor is produced.

**Nomenclature**

$d_p$  : Particle diameter (cm).

F: Number of factors of factorial method (-).

Fr: Froude number (-).

g: Gravitational acceleration ( $m/s^2$ ).

$h_{i-j}$  : Height between two pressure taps (m)

$h_T$  : Total height of the reactor (m).

L: Number of levels of factorial method (-).

$U_{mf}$  : Minimum fluidization velocity (cm/s).

$U_l$  : Superficial liquid velocity (cm/s).

$U_g$  : Superficial gas velocity (cm/s).

$U_t$  : Terminal velocity (cm/s).

$v_l$  : Superficial liquid velocity (cm/s).

$v_g$  : Superficial gas velocity (cm/s).

We: Weber number (-).

$\Delta P_{i-j}$  : Pressure between two pressures taps (mbar).

$\Delta P_t$  : Pressure difference along the bed (mbar).

$\varepsilon_{gi-j}$  : Gas holdup between two pressure taps (-).

$\varepsilon_{gav}$  : Average gas holdup for bubble column (-).

$\varepsilon_l$  : Liquid holdup (-).

$\varepsilon_s$  : Solid holdup (-).

$\rho_l$  : Density of the liquid ( $gm/cm^3$ ).

$\rho_p$  : Density of the particle ( $gm/cm^3$ ).

**References**

1. Prins A., ed. E. Dickinson in Food Emulsions and Foams, Royal Society of Chemistry Special Publication, Vol. 58, Cambridge, 1986, p. 30.
2. Bikerman J.J., Foams, Springer, New York, 1973
3. Kister, H.Z., What Caused Tower Malfunctions in the Last 50 Years, Chem. Eng. Res. Des., 80 (1), pp. 5-26, 2003.
4. Thiele, R.; Brettschneider, O.; Repke, J.-U.; Thielert, H.; Wozny, G. Experimental Investigations of Foaming in a Packed Tower for Sour Water Stripping. Ind. Eng. Chem. Res. 7 (42), pp. 1426-1432, 2003.
5. Guitian, J., and Joseph, D. "Process for suppressing foam formation in a bubble column reactor" US patent no. 5922190 date Jul. 13 1999.
6. Miller DN. Gas holdup and pressure drop in bubble column reactors. Ind. Eng. Chem. Process Des. Dev. 1980; 19:371-7.
7. Krishna, R.; Sie, S. T. Design and Scale-up of the Fischer-Tropsch Bubble Column Slurry Reactor. Fuel Process. Technol. 2000, 64, 73.
9. Hyndman CL, Larachi F, Guy C. Understanding gas-phase
10. hydrodynamics in bubble columns: a convective model based on kinetic theory. Chem. Eng Sci 1997; 52:63-77.
7. Reilly I. G., Scott D. S., De Bruijn T, Jain A, Piskorz J. A correlation for gas holdup in turbulent coalescing bubble columns. Can J Chem Eng 1986; 64:705-17.

- 10.** Letzel, H. M.; Schouten, J. C.; Krishna, R.; van den Bleek, C. M. Gas Holdup and Mass Transfer in Bubble Column Reactors Operated at elevated Pressure. *Chem. Eng. Sci.* 1999, 54, 2237.
- 11.** Jordan, U. and Schumpe, A. The Gas Density Effect on Mass Transfer in Bubble Columns with Organic Liquids. *Chem. Eng. Sci.* 2001, 56, 6267.
- 12.** Behkish, A.; Men, Z.; Inga, J. R.; Morsi, B. I. Mass Transfer Characteristics in a Large-Scale Slurry Bubble Column with Organic Liquid Mixtures. *Chem. Eng. Sci.* 2002, 57, 3307.
- 13.** Vandu, C. O.; Koop, K.; Krishna, R. Volumetric Mass Transfer Coefficient in a Slurry Bubble Column Operating in the Heterogeneous Flow Regime. *Chem. Eng. Sci.* 2004, 59, 5417.
- 14.** Lau, R.; Peng, W.; Velazquez-Vargas, L. G.; Yang, G. Q.; Fan, L. S. Gas-Liquid Mass Transfer in High-Pressure Bubble Columns. *Ind. Eng. Chem. Res.* 2004, 43, 1302.
- 15.** Chaumat, H.; Billet-Duquenne, A. M. ; Augier, F. ; Mathieu, C. ; Delmas, H. Mass Transfer in Bubble Column for Industrial Conditions - Effects of Organic Medium, Gas and Liquid Flow Rates and Column Design. *Chem. Eng. Sci.* 2005, 60, 5930.
- 16.** Yang, W. G.; Wang, J. F.; Wang, T. F.; Jin, Y. Experimental Study on Gas -Liquid Interfacial Area and Mass Transfer Coefficient 2005.

17. Tang, W. T.; Fan, L.S. Hydrodynamics of a Three-Phase Fluidized Bed Containing Low-Density Particles. *AIChE J.* 1989, 35, 355.
18. Yang, W. G.; Wang, J. F.; Zhou, L. M.; Jin, Y. Gas-Liquid Mass Transfer Behavior in Three-Phase CFB Reactors. *Chem. Eng. Sci.* 1999, 54, 5523.
19. Kato Y., Nishiwaki A., Kago T., Fukuda T., Tanaka S. Gas holdup and overall volumetric absorption coefficient in bubble columns with suspended solid particles. *Trans. Inst. Chem. Eng.* 1973, 13:562–7.
20. Deckwer W.D., Louisi Y., Zaidi A., Ralek M. Hydrodynamic properties of the Fisher–Tropsch slurry process. *Ind. Eng. Chem. Process Des. Dev.* 1980; 19:699–708.
21. Sada E., Katoh S., Yoshil H. Performance of the gas–liquid bubble column in molten salt systems. *Ind. Eng. Chem. Process Des. Dev.* 1984; 23:151–4.
22. Pino L.Z., Solari R.B., Siuier S., Estevez L.A., Yopez M.M., Saez A.E.. Effect of operating conditions on gas holdup in slurry bubble columns with a foaming liquid. *Chem Eng Commun* 1992; 117:367–82.
23. Krishna R., De Stewart J.W.A., Ellenberger J., Martina G.B., Maretto C. Gas holdup in slurry bubble columns: effect of column diameter and slurry concentrations. *AIChE J* 1997; 43:311–6.

- 24.** Dargar, P., Macchi, A. Effect of Surface-Active Agents on the Phase Holdups of Three-Phase Fluidized Beds. *Chem. Eng. Process.* **2006**, 45, 764.
- 25.** Hutzler, S., Cox, S.J., Wang, G. (2005) "Foam drainage in two dimensions", *Colloids Surfaces A*, **263**, 178.
- 26.** Garrett P. Defoaming. Theory and Industrial Applications. New York: Marcel Dekker, Inc.(1993).
- 27.** Armstrong, E. R., C. G. J. Baker, and M. A. Bergougnou. Effects of Solids Wettability on the Characteristics of Three-phase Fluidization. *Fluidization Technology*, 127, p.405, Hemisphere, Washington, DC (1976).
- 28.** Frye, G. and John C. Berg. Antifoam Action by Solid Particles. *Journal of Colloid and Interface Science*, 1989,127, No. 1, 222-238
- 29.** Tsutsumi, A., A. Ghosh Dastidar and L. Fan. Characteristics of Gas-Liquid- Solid Fluidization with Nonwetable Particles. *AIChE Journal*, 1991, 37, No. 6, 951- 952.
- 30.** Perry, R.H., Green, D.W., and Moloney, J.O., "Perry's Chemical Engineer's Handbook", McGraw Hill, 6<sup>th</sup> edition, 1987.
- 31.** Maloney, J.E. and Oakes, T.R. Hydrophobic Silica. US patent no. 4443357(1984).
- 32.** Mata, C. and D.D. Joseph. Foam control using a fluidized bed of hydrophobic particles. *Int. J. Multiphase Flow*, 1997: 25(1), 63-85.

**Figures**

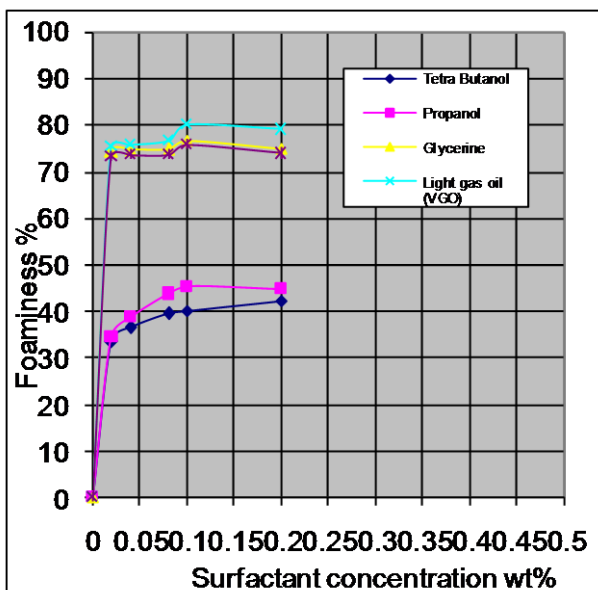

**Fig. (2)** Foaminess of different type of surface active agents as a function of concentration.

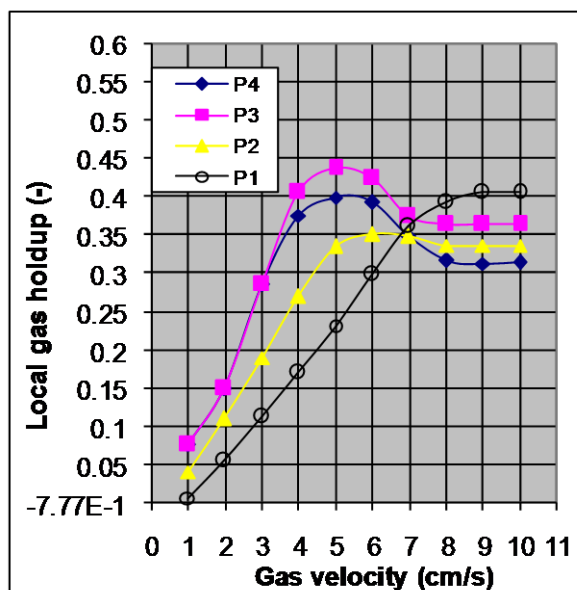

**Fig. (4)** Local gas hold-up versus superficial velocity in various sections of the column at a liquid velocity of 0.152 (cm/s) and with 10% volume fraction of hydrophilic particles of mean size (200-300)  $\mu\text{m}$ .

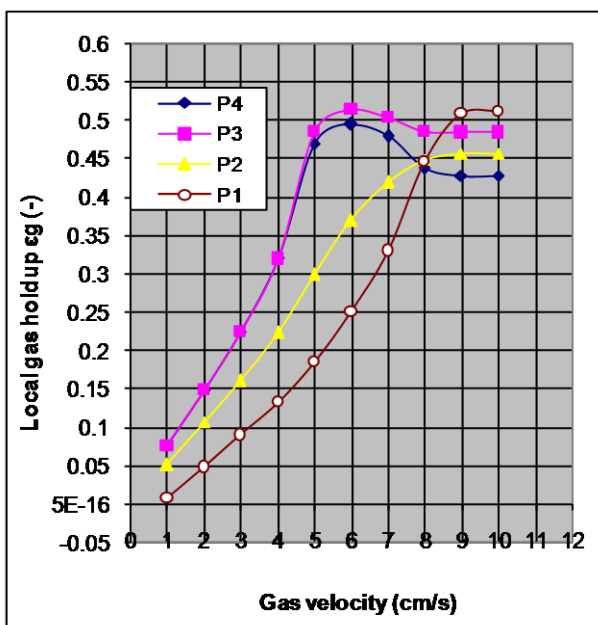

**Fig. (3)** Local gas hold-up versus superficial velocity in various sections of the column at a liquid velocity of 0.152 (cm/s) and without particles.

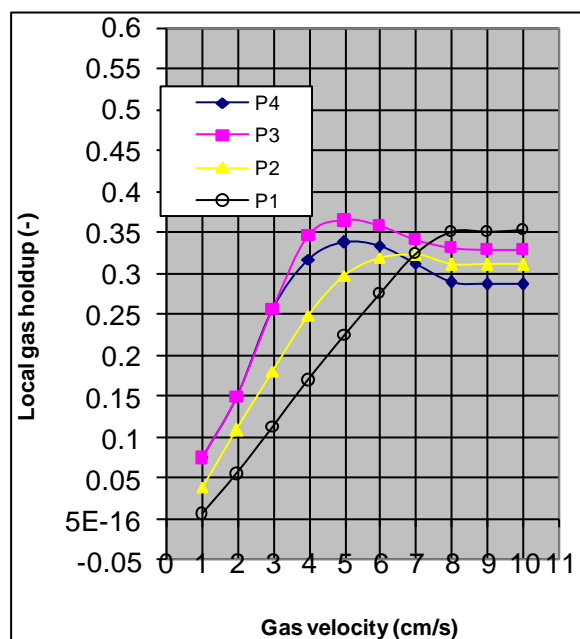

**Fig.(5)** Local gas hold-up versus superficial velocity in various sections of the column at a liquid velocity of 0.152 (cm/s) and with 10% volume fraction of hydrophobic particles of mean size (200-300)  $\mu\text{m}$ .

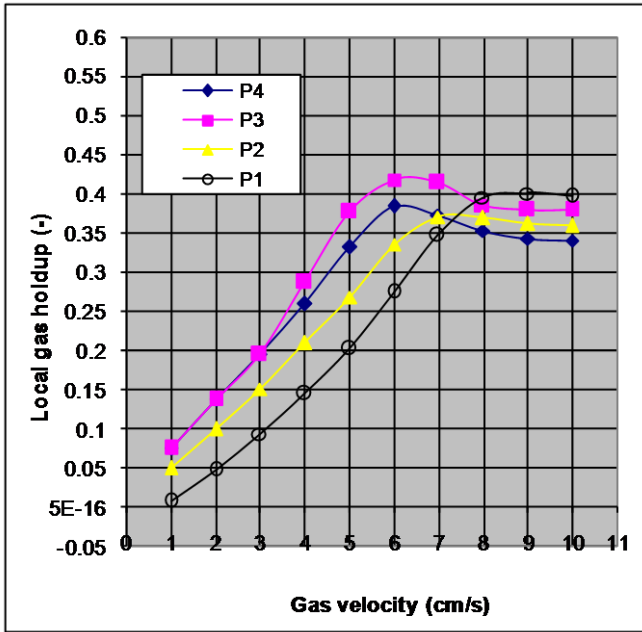

Fig. (6) Local gas hold-up versus superficial velocity in various sections of the column obtained by pressure transducers at a liquid velocity of 0.152 (cm/s) and with 10% volume fraction of hydrophilic particles of mean size (700-900)  $\mu\text{m}$ .

F

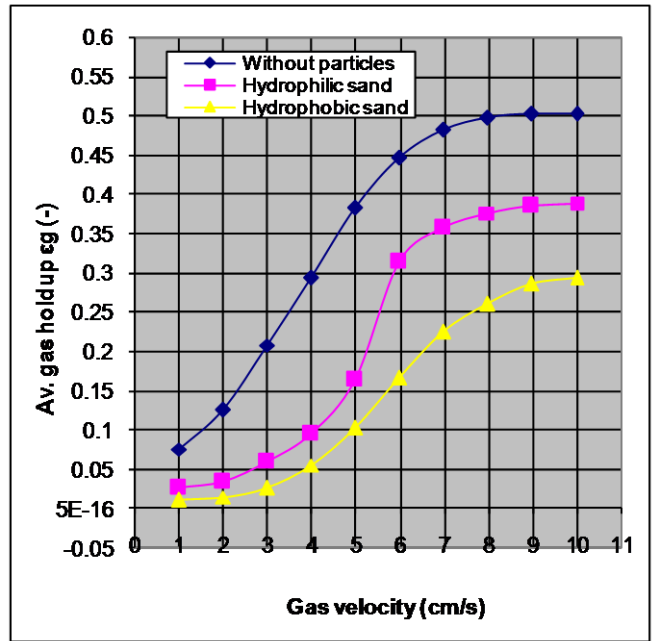

Fig. (8) Average gas holdup as a function of gas velocity at a liquid velocity of 0.152 cm/s, for 1%wt.Glycerine solution without particles and, with 10% volume fraction of particles hydrophilic and hydrophobic sand mean size (200-300)  $\mu\text{m}$ .

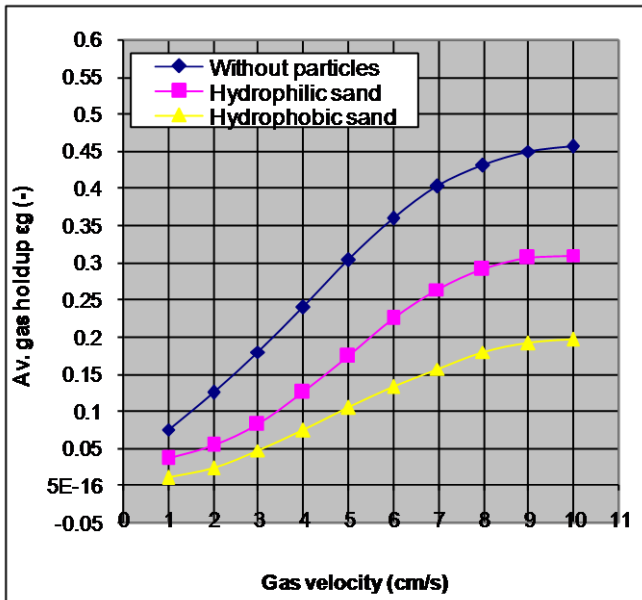

Fig. (7) Local gas hold-up versus superficial velocity in various sections of the column obtained by pressure transducers at a liquid velocity of 0.152 (cm/s) and with 10% volume fraction of hydrophobic particles of mean size (700-900)  $\mu\text{m}$ .



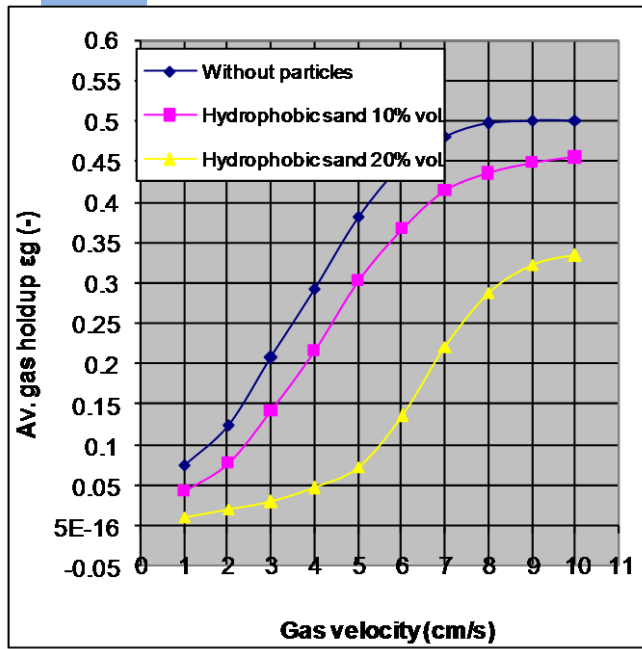

Fig. (9) Average gas holdup as a function of gas velocity a liquid velocity of 0.3 cm/s, for a 1%wt. Glycerin solution without particles and,with 10% volume fraction of (mean size = 200-300  $\mu\text{m}$ ).

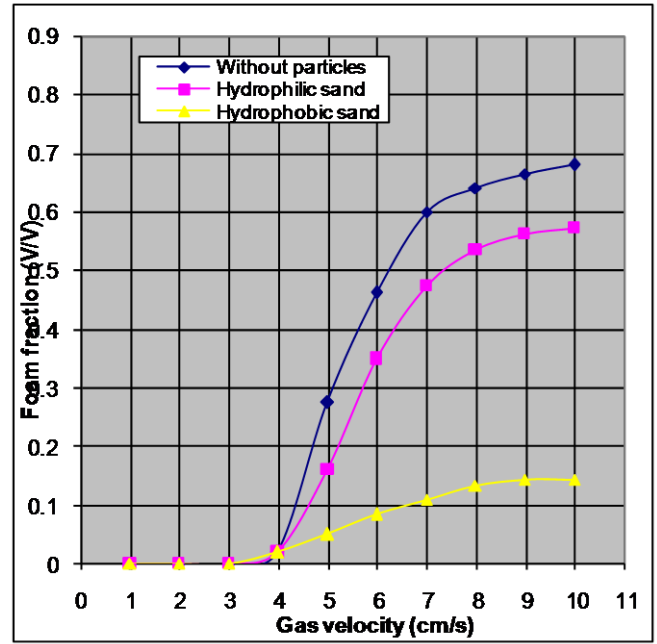

Fig. (11) Average gas holdup as a function of gas velocity a liquid velocity of 0.152 cm/s, for a 1%wt. Glycerin solution without particles and, with 10% and 20% volume fraction of particles hydrophobic sand (mean size = 700-900  $\mu\text{m}$ ).

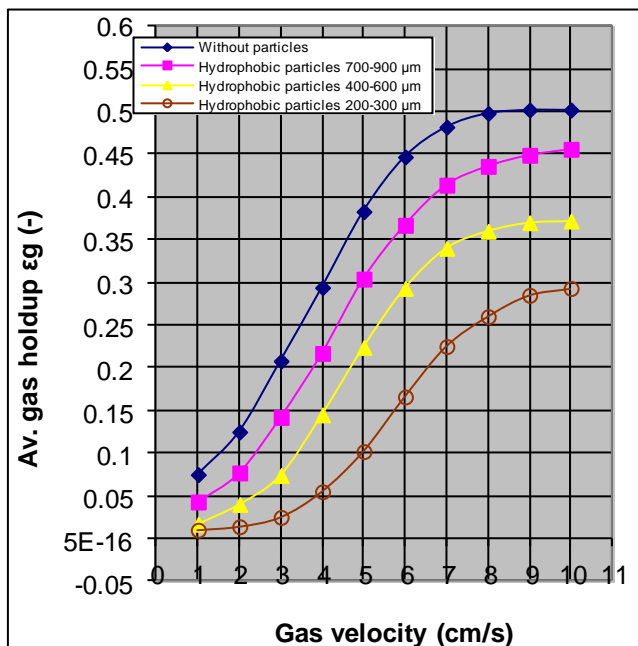

Fig. (10) Average gas holdup as a function of gas velocity a liquid velocity of 0.152 cm/s, for a 1%wt. Glycerin solution without particles and, with 10% volume fraction of particles hydrophobic sand of different sizes.

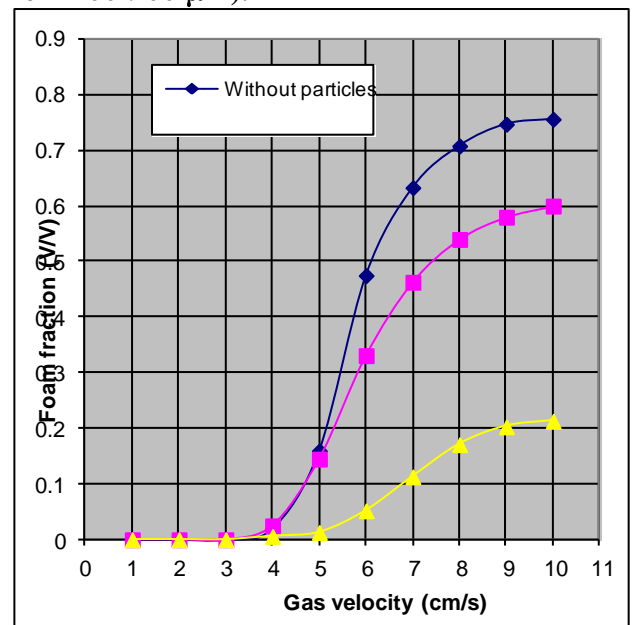

Fig. (12) foam fraction against gas velocity at a liquid velocity of 0.152 cm/s, for 1% wt.glycerine solution without particles and, with 10% volume fraction of particles hydrophilic sand and hydrophobic sand(mean size = 200-300)  $\mu\text{m}$ .

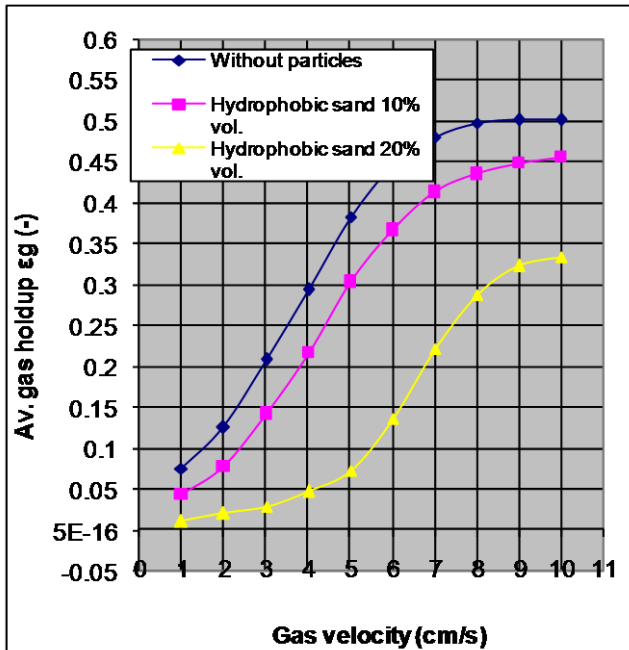

Fig. (13) Foam fraction versus gas velocity a liquid velocity of 0.3 cm/s, for a 1%wt. Glycerin solution without particles and, with 10% volume fraction of particles hydrophilic sand and hydrophobic sand (mean size = 200-300)  $\mu\text{m}$ .

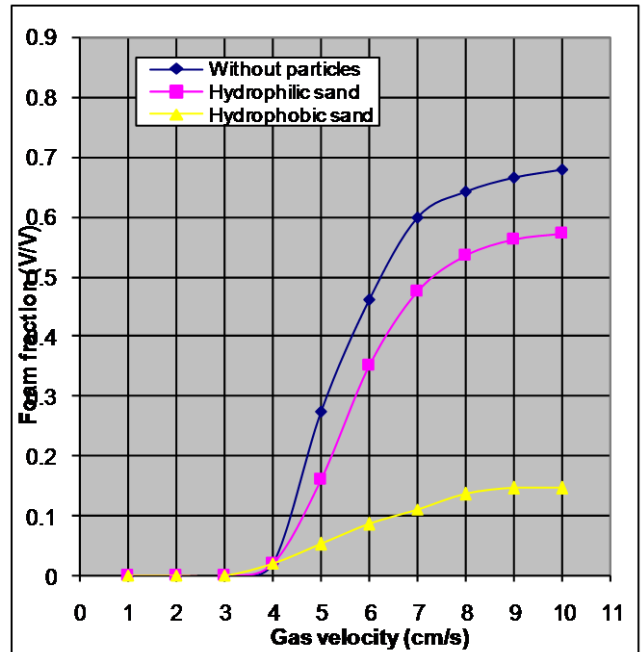

Fig. (15) Foam fraction as a function of gas velocity a liquid velocity of 0.0764 cm/s, for a 1%wt. Glycerin solution without particles and, with 10% volume fraction of particles hydrophilic sand and hydrophobic sand (mean size = 400-600)  $\mu\text{m}$ .

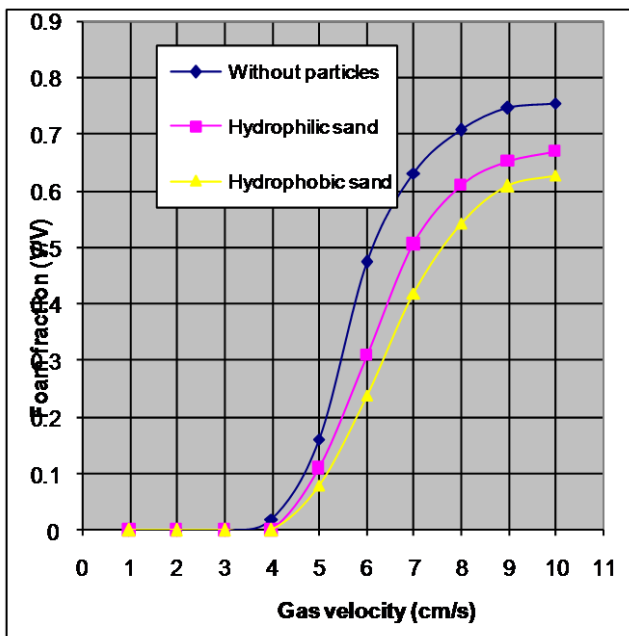

Fig. (14) Foam fraction as a function versus gas velocity a liquid velocity of 0.152 cm/s, for a 1%wt. Glycerin solution without particles and, with 10% volume fraction of particles hydrophilic sand and hydrophobic sand (mean size = 700-900)  $\mu\text{m}$ .

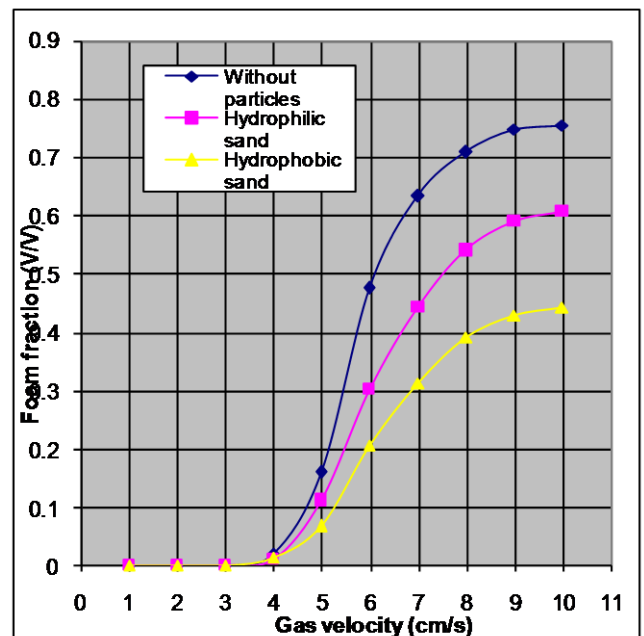

Fig. (16) Foam fraction against gas velocity a liquid velocity of 0.152 cm/s, for a 1%wt. Glycerin solution without particles and, with 10% volume fraction of particles hydrophilic sand and hydrophobic sand (mean size = 400-600)  $\mu\text{m}$ .

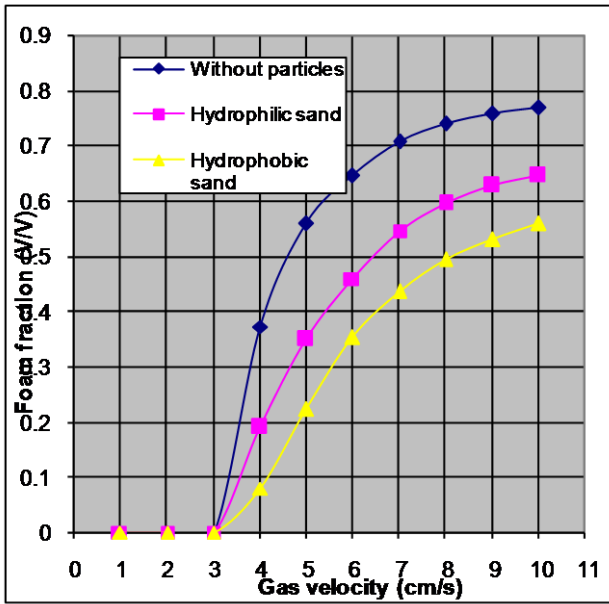

Fig. (17) Foam fraction against gas velocity a liquid velocity of 0.152 cm/s, for a 1%wt. Glycerin solution without particles and, with 10% volume fraction of particles hydrophobic sand of different sizes.

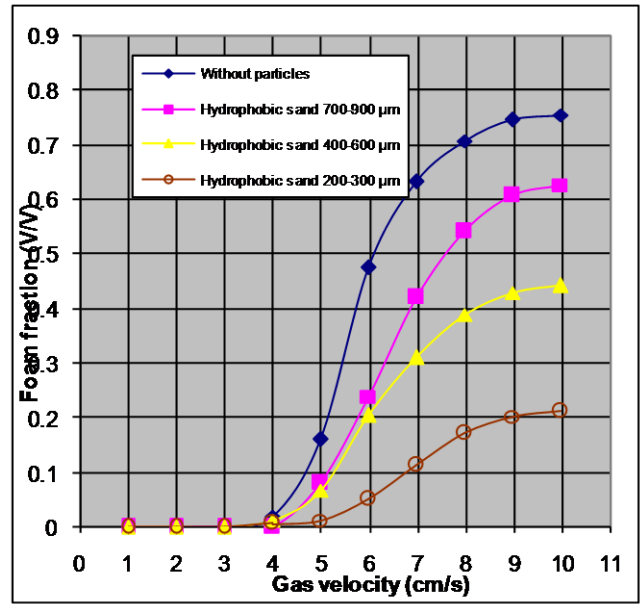

Fig. (19- a) Axial concentration profiles for 10%vol hydrophilic particles (200-300) μm diameter at different liquid velocities and  $u_g = 2$  (cm/s).

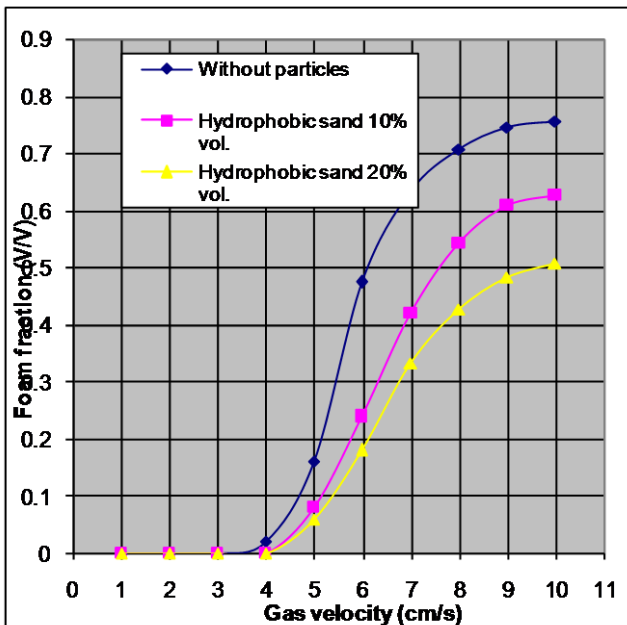

Fig. (18) Foam fraction against gas velocity a liquid velocity of 0.152 cm/s, for a 1%wt. Glycerin solution without particles and, with 10% and 20% volume fraction of particles hydrophobic sand (mean size = 700-900 μm).

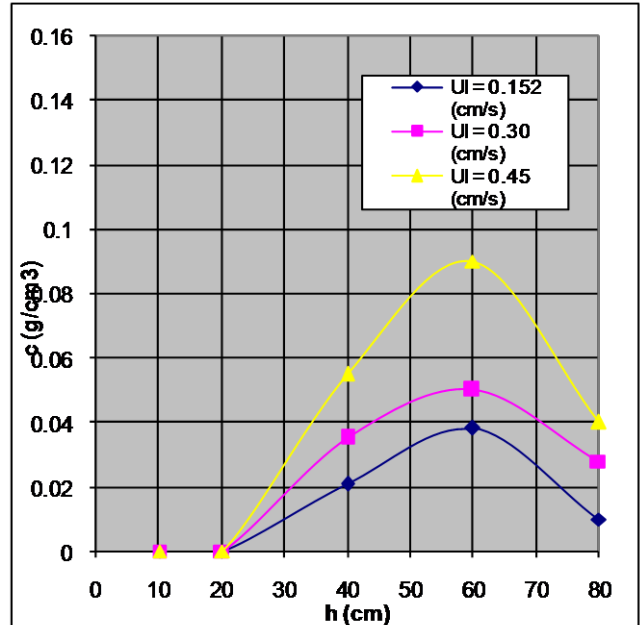

Fig. (19-b) Axial concentration profiles for 10%vol hydrophilic particles (200-300 μm) diameter at different liquid velocities and  $u_g = 4$  (cm/s).

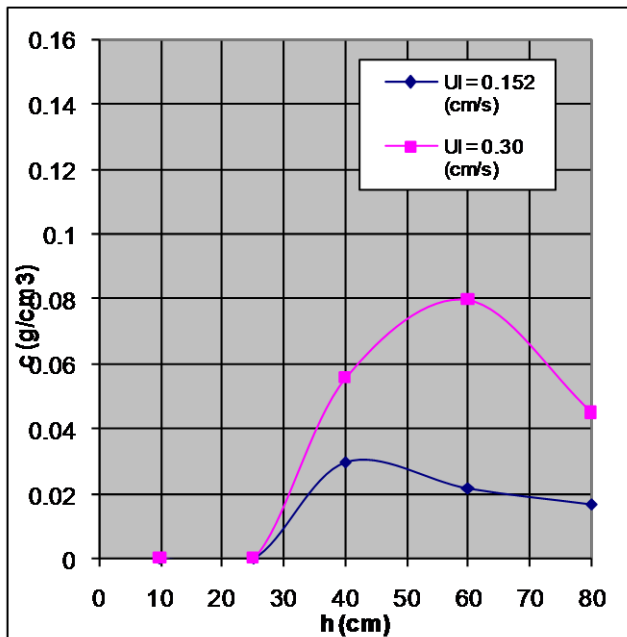

Fig. (19-c) Axial concentration profiles for 10%vol hydrophilic particles (200-300 μm) diameter at different liquid velocities and  $u_g = 8$  (cm/s).

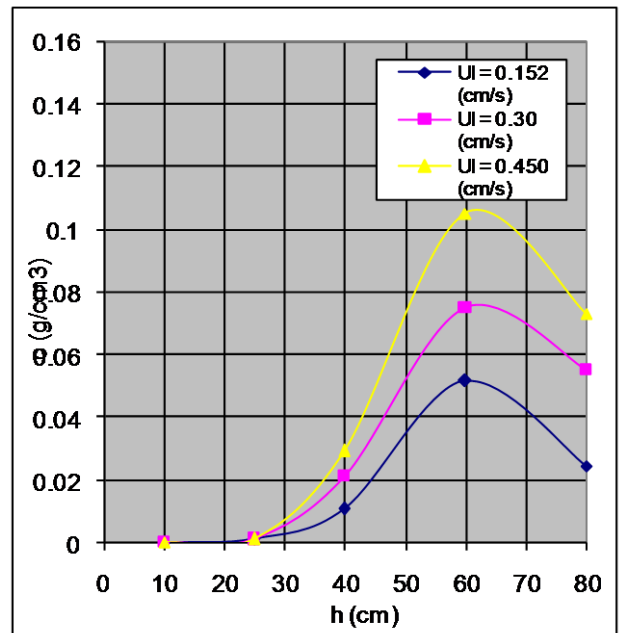

Fig. (20-b) Axial concentration profiles for 10%vol hydrophobic particles (200-300 μm) diameter at different liquid velocities and  $u_g = 4$  (cm/s).

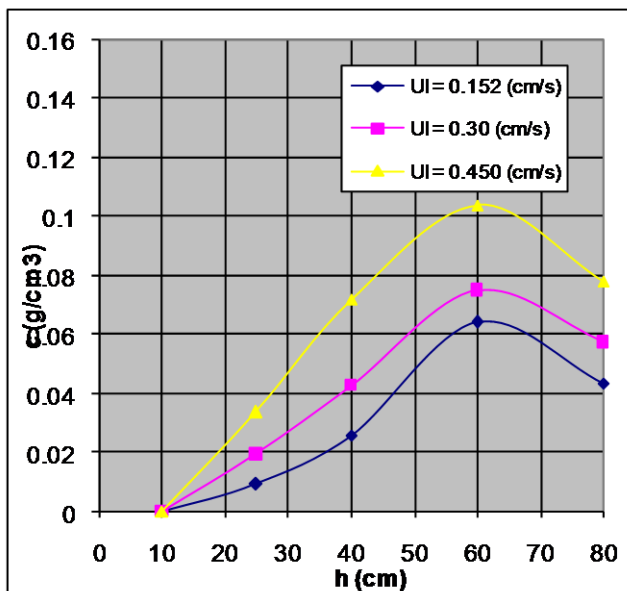

Fig. (20-a) Axial concentration profiles for 10%vol hydrophobic particles (200-300 μm) diameter at different liquid velocities and  $u_g = 2$  (cm/s).

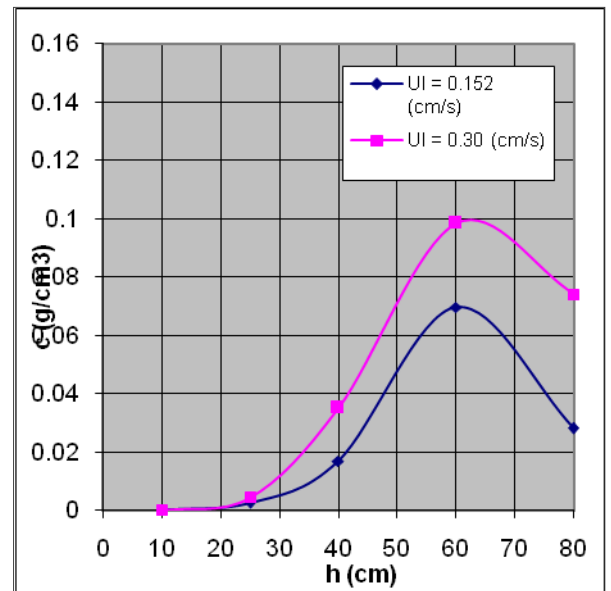

Fig. (20-c) Axial concentration profiles for 10%vol hydrophobic particles (200-300 μm) diameter at different liquid velocities and  $u_g = 8$  (cm/s).